



PDHonline Course M246 (4 PDH)

HVAC Ducting – Principles and Fundamentals

Instructor: A. Bhatia, B.E.

2020

PDH Online | PDH Center

5272 Meadow Estates Drive
Fairfax, VA 22030-6658
Phone: 703-988-0088
www.PDHonline.com

An Approved Continuing Education Provider

CONTENTS

1.0.	INTRODUCTION	1
2.0.	DUCT COMPONENTS	1
3.0.	DUCT CLASSIFICATION	2
3.1	Velocity Classification	2
3.2	Pressure classification	3
4.0.	DUCT MATERIALS	4
4.1	Metallic Ducts	4
4.2	Non Metallic ducts	5
5.0.	DUCT SHAPES	6
5.1	Round Ducts	7
5.2	Rectangular Ducts	7
5.3	Oval Ducts	8
6.0.	SUPPLY DUCT CONFIGURATIONS	8
6.1	Extended Plenum Systems	8
6.2	Reducing Trunk System	10
6.3	Spider System	11
6.4	Radial System	11
6.5	Perimeter Loop System	12
7.0.	RETURN DUCT SYSTEMS	12
7.1	Return Duct Configurations	13
7.2	Maintaining Neutral Pressure	13
8.0.	DUCT SIZING	13
8.1	Constant friction loss method	14
8.2	Velocity Reduction Method	17
8.3	Static Regain Method	19
9.0.	DUCT CONSTRUCTION & REINFORCEMENT	20
9.1	Duct Sheet Metal Thickness	20
9.2	Duct Hanger Spacing	21
10.0.	RECOMMENDED PRACTICES FOR DUCTING LAYOUT	21
10.1	Zoning	22
10.2	Selecting Outlets and Intakes for Supply, Return and Extract	22
10.3	Location of supply, return and exhaust registers	24

10.4	Mechanical Rooms	25
10.5	Duct Routing & Layout	25
10.6	Duct Locations	27
10.7	Duct Fittings and Transitions	28
10.8	Aspect Ratio	32
10.9	Standard Duct Sizes	32
11.0.	DUCTWORK DESIGN CONSIDERATIONS	33
11.1	Duct Frictional Resistance	33
11.2	Duct Equivalent Length	35
11.3	Ductwork System Effect	35
11.4	Installation Issues	37
11.5	Ductwork Insulation	38
11.6	Ductwork Air Leakage	39
11.7	Testing Methods and Equipment	40
11.8	Ductwork Sealing	41
11.9	Volume Flow Rate Measurements	42
11.10	Ductwork Pressure Balancing	43
11.11	Duct Noise Considerations	43
11.12	Energy Conservation	45
11.13	Coordination between Design Specialties	46
12.0.	DUCTWORK TESTING & SYSTEM PERFORMANCE	47
12.1	Provisions during Design for Testing, Adjusting, and Balancing	48
13.0.	DUCT CLEANING	50
13.1	Duct Cleaning Methods	51

HVAC Ducting – Principles and Fundamentals

A. BHATIA, B.E.

1.0. INTRODUCTION

Most air conditioning and heating systems require some form of duct work to channel or direct the air to places where the conditioned air is needed. There are many types of ductwork available and often times the ductwork can make a big difference in your utility bills. For that reason, it is important that the ductwork is designed and installed correctly. A poor installation job will result in poor performance, bad air flow, leaky duct systems, and higher than usual utility bills. Another important factor in the installation process is to make sure the duct work is sized properly. Oversizing systems cost more and does not maintain the desired air flow and undersized duct work causes the system to strain mechanically and can be noisy.

Several issues must be considered in an effective design. A primary issue is the tradeoff between the initial cost of the duct system and the energy cost of the air distribution system; larger ducts require a larger initial investment, but result in lower fan energy costs over the life of the system. Other issues include space available, noise level, capacity for expansion, appearance etc. It is important that the air conditioning ductwork system be designed for the air conditioning load. Each room or space of the facility should be evaluated and a determination of how much air flow will be required to ensure that each room remains at a desirable and comfortable temperature.

This course provides a basic overview of HVAC ducting system.

2.0. DUCT COMPONENTS

Starting with the basics, let's start at the most elementary level by identifying components of a duct system. A duct system is a network of round or rectangular tubes—generally constructed of sheet metal, fiberglass board, or a flexible plastic and wire composite—located within the walls, floors, and ceilings. Usually, you can see only the outlet, which is a register covered with grillwork.

The purpose of a duct system is to transmit air from the central air source to the air diffusers located in the building control zones. Figure below shows a central heating furnace connected to supply and return air ductwork. The furnace is connected to the air plenum at the starting point. Furnace fan/s draw air in through grilles called returns and force air through the plenum and into the conditioned space through supply registers.

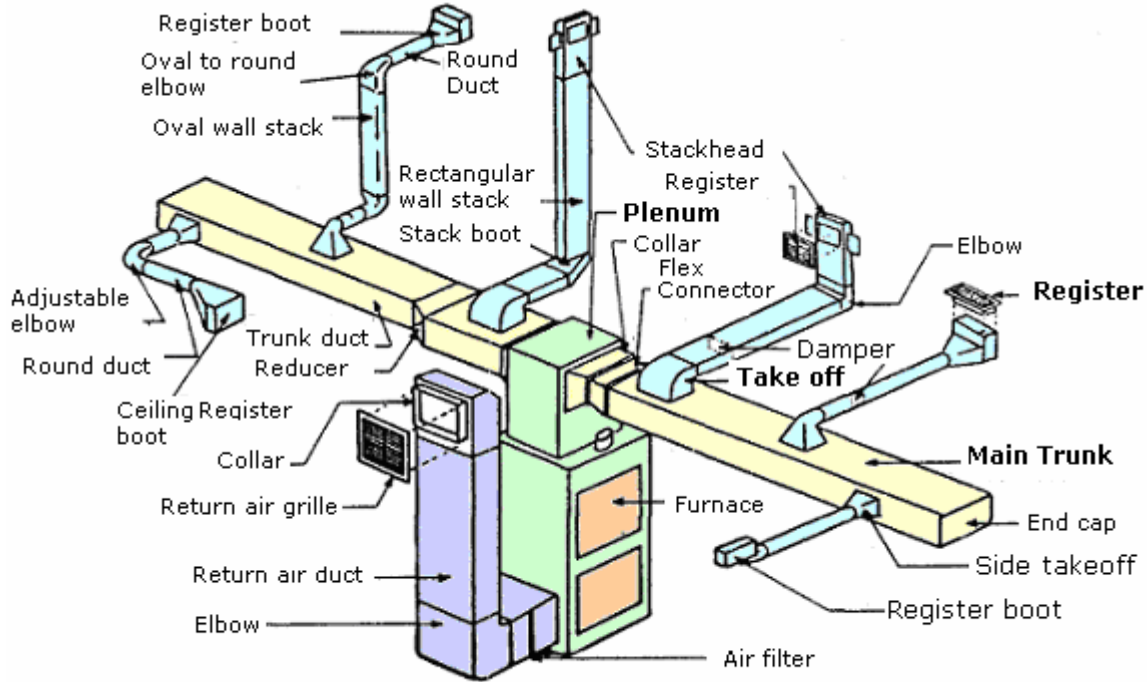

COMPOSITE DUCT SYSTEM

What is the Plenum? The plenum is the main part of the supply and return duct system that goes directly from the air handler or furnace to the Main Trunk.

What is the Main Trunk? The Main Trunk(s) are the part of the duct system that all the air from the system is going to travel in before we "take off" the main plenum to the "diffusers" or grilles.

What is a Take Off? A "take off "is that part of the system where we take the air off the trunk to supply air to the living area of the house. Then from the "take off" we will go directly to the Grilles, diffuser or registers.

What is a Grille, diffuser or register? A system of fixed or adjustable vanes covering an opening through which air is discharged; Diffuser is an outlet devise discharging supply air in a direction radially to the axis of entry. Register is a grille equipped with a damper control valve.

3.0. DUCT CLASSIFICATION

Duct systems are classified in terms of their application, velocity, and pressure.

3.1 Velocity Classification

Ducts are classified according to the velocity they are subjected to.

Ducts are classified into 3 basic categories:

1. Low Velocity Duct Systems: Low-velocity ducts are characterized by air velocities in the range of 400 to 2000 feet per minute (fpm).
2. Medium Velocity Duct Systems: Medium-velocity (MV) duct systems are characterized by air velocities in the range of 2000 to 2500fpm.
3. High Velocity Duct Systems: High-velocity (HV) duct systems are characterized by air velocities in the range of 2500 to 3500 fpm.

Low-velocity ductwork design is very important for energy efficiency in air distribution systems. Low-velocity design will lead to larger duct sizes, but it may be worth since, doubling of duct diameter will reduce friction loss by a factor of 32 times and will be less noisy. The low-velocity systems occupy more space and have higher first costs; facility owners are often reluctant to provide the space for more expensive ductwork, but significant energy savings can be realized even when the ductwork is only increased by one standard size.

Low Velocity System Guidelines

Some guidelines for determining the maximum airflow velocity to use in selected applications of low-velocity systems include:

Application	Velocity
Residences	600 fpm
Theaters, churches, auditoriums	800 fpm
Apartments, hotels rooms	1,000 fpm
Offices, libraries	1,200 fpm
Stores, restaurants, banks	1,500 fpm
Cafeteria	1,800 fpm

3.2 Pressure classification

Duct systems are also divided into three pressure classifications, matching the way supply fans are classified. The pressures are total pressure and include all losses through the air source unit, the supply ductwork, and the air terminals, return air grilles, and return ductwork. The pressure classifications are:

Low Pressure:	Up to 4.0 in-wg -	Class I Fan
Medium Pressure:	From 4.0 to 6.0 in-wg -	Class II Fan
High Pressure:	From 6.0 to 12 in-wg -	Class III Fan

As a good engineering practice -

1. Primary air ductwork (fan connections, risers, main distribution ducts) shall be medium pressure classification.
2. Secondary air ductwork (run-outs/branches from main to terminal boxes and distribution devices) shall be low pressure classification.

Velocity classification v/s Pressure classification –

Generally speaking,

- a. Duct strength, deflection and leakage are more functions of pressure than of velocity.
- b. Noise, vibration and friction loss are more related to velocity than to pressure.

4.0. DUCT MATERIALS

Ducting may be categorized according to the materials of construction and are either metallic or non-metallic ducts. The majority of ducts are constructed of metal and installed by tradesmen called sheet metal workers. In fact, sheet metal use in HVAC is greater than all other materials combined. The steel and aluminum used for ductwork is a "high achiever" in the 21st-century move toward sustainable buildings because of the high recycling rates and cleanliness.

4.1 Metallic Ducts

A great majority of metallic ducts is made of galvanized steel. Next in popularity in metal ducts is aluminum. Aluminum ducts are light in weight, but basic cost per pound is higher than galvanized steel. Other metals used under special circumstances are copper and stainless steel and non-metallic ducts may include glass fiber, compressed paper, plastic, cement-asbestos, vitrified clay, and concrete.

Each material has characteristics that may favor its use in specialized applications. Sheet metal has a number of advantages: It is made from recycled materials; it is non-combustible; it is the sturdiest material; and it is the easiest to clean. Following is a list of key characteristic of duct materials:

1. **Galvanized Steel** - Widely used as a duct material for most air handling systems; not recommended for corrosive product handling or temperatures above 400°F. Advantages

include high strength, rigidity, durability, rust resistance, availability, non-porosity, workability, and weldability.

2. **Carbon Steel (Black Iron)** - Applications include flues, stacks, hoods, other high temperature duct systems, and ducts requiring paint or special coating. Advantages include high strength, rigidity, durability, availability, weldability, and non-porosity. Some limiting characteristics are corrosion resistance and weight.
3. **Aluminium** - Aluminium ducting is most commonly used for clean room applications. These are also preferred systems for moisture laden air, special exhaust systems and ornamental duct systems. Some advantages include weight and resistance to moisture corrosion. Limiting characteristics include low strength, material cost, weldability, and thermal expansion.
4. **Stainless Steel** - Used in duct systems for kitchen exhaust, moisture laden air, and fume exhaust. Advantages include high resistance to corrosion from moisture and most chemicals and the ability to take a high polish. Limiting characteristics include labour and material costs, workability, and availability.
5. **Copper** - Copper applications include duct systems exposed to outside elements and moisture laden air, certain chemical exhaust, and ornamental ductwork. Advantages are durability and corrosion resistance and that it accepts solder readily and is nonmagnetic. Limiting characteristics are cost, ductility, electrolysis, thermal expansion, and stains.

4.2 Non Metallic ducts

1. **Fibreglass Reinforced Plastic (FRP)**: Applications include chemical exhaust, scrubbers, and underground duct systems. Limiting characteristics include cost, weight, range of chemical and physical properties, brittleness, fabrication (necessity of moulds and expertise in mixing basic materials), and code acceptance.

Fibreglass duct board is insulated and sealed as part of its construction. Fibreglass duct board provides excellent sound attenuation, but its longevity is highly dependent on its closure and fastening systems. Resistance to corrosion and ease of modification are advantages of FRP. It is usually used to form rectangular supply and return trunks, branches, and plenums, although it can be used for run outs as well.

2. **Polyvinyl Chloride (PVC)**: Applications are exhaust systems for chemical fumes and underground duct systems. Advantages include resistance to corrosion, weight, weldability, and ease of modification. Limiting characteristics include cost, fabrication, code acceptance, thermal shock, and weight.
3. **Polyvinyl Steel (PVS)**: Applications include underground duct systems, moisture laden air, and corrosive air systems. Some advantages are resistance to corrosion, weight,

workability, fabrication, and rigidity. Some limiting characteristics include temperature limitations (250°F maximum), weldability, code acceptance, and susceptibility to coating damage.

4. **Flexible Nonmetallic Duct:** Flexible or flex duct consists of a duct inner liner supported on the inside by a helix wire coil and covered by blanket insulation with a flexible vapor-barrier jacket on the outside. Flex duct is often used for run outs, with metal collars used to connect the flexible duct to supply plenums, trunks, and branches constructed from sheet metal or duct board. Flex duct is also commonly used as a return duct. Flex duct is factory-insulated and has fewer duct connections and joints. However, these connections and joints must be mechanically fastened using straps and sealed using mastic. Flex duct is easily torn, crushed, pinched, or damaged during installation. It has the highest resistance to air flow. Consequently, if used, it must be properly specified and installed.

Flex duct, which is used extensively in commercial construction, has more than 60% higher pressure drop than galvanized metal duct of the same diameter. Flex duct runs should be limited to six feet or less. When longer runs must be used, make sure the duct is well supported at five foot intervals to minimize sag. Flex duct should be fully extended to minimize pressure drop.

5. **Concrete:** Concrete can be used for underground ducts and air shafts. Advantages include compressive strength and corrosion resistance. Cost, weight, porosity, and fabrication (requires forming processes) are some limiting characteristics.
6. **Rigid Fibrous Glass:** Fibrous glass ducts are fabricated from sheets of materials that have been manufactured from resin bonded inert and inorganic glass fibers. A factory applied facing (typically aluminium or reinforced aluminium) is applied to one face, and serves as a finish and a vapour barrier. Fibrous glass air ducts have been limited to 2 in-WG pressure and below.

Advantages include weight, thermal insulation and vapor barrier, acoustical qualities, ease of modification, and inexpensive tooling for fabrication. Limiting characteristics include cost, susceptibility to damage, system pressure, and code acceptance.

5.0. DUCT SHAPES

Ducts are usually fabricated in round or rectangular shapes. Both types have advantages and disadvantages, and both find applications where one is definitely superior to the other.

Recently, a round spiral duct that has been stretched to an oval shape has been utilized more frequently. Following are the key characteristics of common duct shapes:

5.1 Round Ducts

Salient features of round ducts are listed below:

1. A round duct has a smaller cross-sectional area and has less duct wall exposed to moving air. An 18 inch diameter duct, for example, has the same air-carrying capacity as a 26" x 11" rectangular duct. The round duct has a cross-sectional area 254.5 sq-in and a perimeter of 4.7 ft, while the rectangular duct has 286 sq-in area and a perimeter of 6.2 ft. The rectangular duct thus has 32% more metal in it and would cost proportionately more. Also the insulation, supports and labour shall be higher for rectangular ducts of similar capacity.
2. Round ducts have a smaller pressure drop per unit area of all duct types and are generally the most cost effective. Round ductwork provides maximum air-carrying capacity with minimum pressure loss.
3. Round spiral duct leaks less than rectangular duct due the lack of longitudinal joints and generally fewer transverse joints when run in long straight duct sections.
4. The low-frequency sound is well contained a round duct. The flat sections of rectangular duct and wide flat oval duct behave like a drum, easily transmitting low frequency duct rumble.
5. Round ductwork is stiffer than rectangular, is easier to insulate, and can be sealed more easily than rectangular ducts.
6. One big disadvantage of round duct is; they require more clear height for installation. If the net clear height of a furred space above suspended ceiling is, for example, 14 inches, an 18 in diameter duct cannot be installed therein; however, its equivalent 26" x 11" rectangular duct will fit the space easily. A combination of a rectangular plenum and round branches sometimes is a good compromise.

5.2 Rectangular Ducts

Rectangular ducts can be adapted to any space height restrictions and are easily shipped when broken down or nested. They provide flat surfaces for branch tap-ins and they are conveniently fabricated.

For large plenums and duct sections containing many fittings, rectangular duct fittings are usually easier to assemble than round and oval fittings. When rectangular ducts must be used due to space limitations, keep the width-to-height ratio (aspect ratio) low and preferably not exceeding 1:4.

Lining rectangular duct is least expensive since it can be done automatically on coil lines.

Disadvantages are:

- they create higher pressure drop;
- they use more pounds of metal for the same air-flow rate as round duct;

- joint length is limited to the sheet widths stocked by the contractor; and
- Joints are more difficult to seal; also, rectangular transverse joints are more costly to install than round ones.

Rectangular ducts, particularly those with high aspect ratio can transmit excessive noise if not properly supported. If round ducts cannot be installed in a particular space because of height limitations, the main trunk can be constructed of rectangular shape and the branch tap-ins can be round.

5.3 Oval Ducts

Flat oval ducts have smaller height requirements than round ducts and retain most of advantages of the round ducts. However, fittings for flat oval ducts are difficult to fabricate or modify in the field. Other disadvantages of flat oval ducts include: difficulty of handling and shipping larger sizes; a tendency of these ducts to become more round under pressure; and, in large aspect ratios, difficulty of assembling oval slip joints.

6.0. SUPPLY DUCT CONFIGURATIONS

The configuration of a duct system is often like a tree with branches connected to the terminal units and a fan located at the root. In reality ductwork forms a double tree because the fan is in the middle of supply and return/outside air parts of the system.

The two most common supply duct systems are the 'extended plenum' system and the 'radial' system because of their versatility, performance, and economy. The spider and perimeter loop systems are other options depending on space type and other design considerations.

6.1 Extended Plenum Systems

In the extended plenum systems, a large main supply trunk is connected directly to the air handler or its supply plenum. Smaller branch ducts and run outs are connected to the trunk.

There are several variations of the trunk and branch system. An efficient extended plenum system is shown in figure below, which uses a main supply trunk of same one size. In this application, the equipment is centrally located, with a straight trunk duct serving one group of branch outlets and another straight trunk duct serving a similar group of branch outlets. Neither of the trunk ducts exceeds 24 feet.

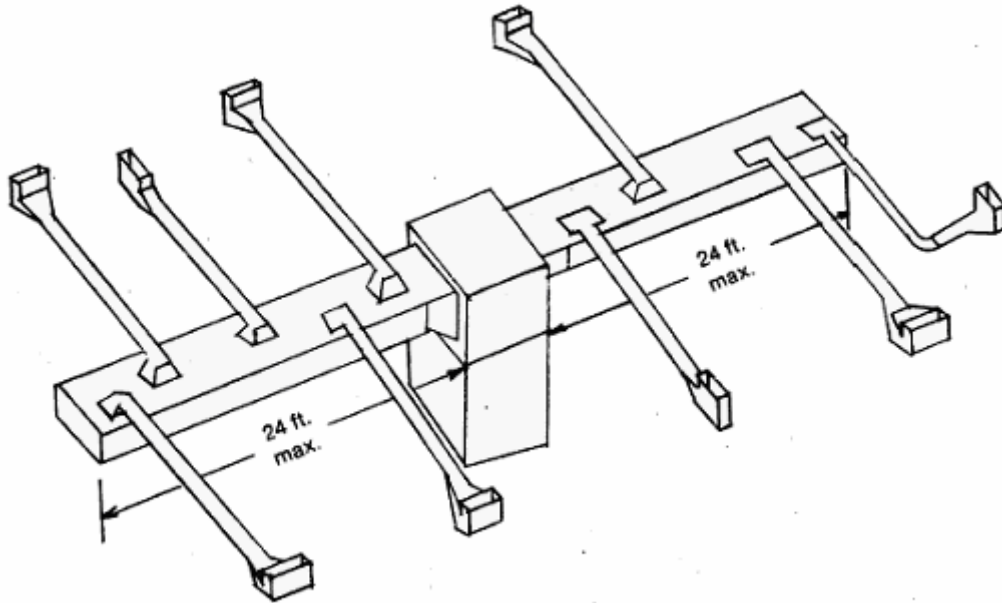

Extended Plenum System (Equipment Centrally Located)

Sometimes it is not practical to locate the equipment centrally. Proximity to a flue on an end wall or other floor-plan considerations may require that equipment be located at one end of the building. This could require trunk ducts in excess of 24 feet. Under these conditions a reduced extended plenum system would be required. Figure below illustrates this application. Note that the trunk duct has been reduced after the first group of branch outlets to maintain sufficient air pressure to the branches closer to the equipment. Also note that trunk ducts of a given size do not exceed 24 feet.

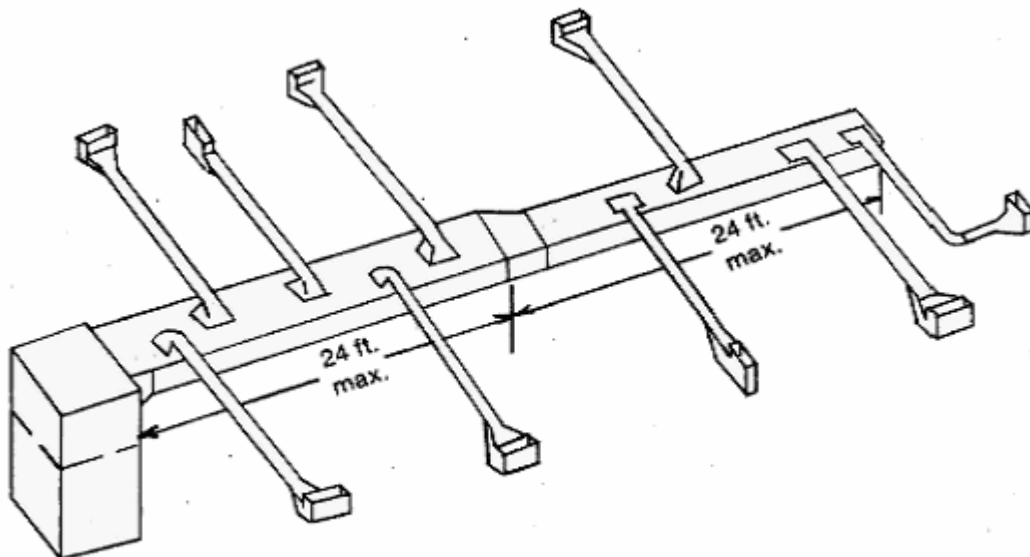

Extended Plenum System (Equipment Located at One End)

The trunk & branch system subject to meeting length criteria is adaptable to most facilities and are easily balanced. The principal design limitation of the extended plenum system is the

length of single-size trunk duct, which is usually limited to about 24 feet. When this length is exceeded, pressure tends to build up toward the end of the duct, resulting in too much airflow in branches near the ends and insufficient airflow in branches closer to the equipment. In extreme cases where unreduced duct length is excessive, reduced pressures at branch duct takeoffs close to the equipment can actually cause air to be drawn into supply registers rather than being forced out.

Therefore, the extended plenum system with centrally located equipment can be used in spaces up to approximately 50 feet long, depending on register locations in end.

6.2 Reducing Trunk System

A reducing plenum system uses a trunk reduction periodically to maintain a more uniform pressure and air velocity in the trunk, which improves air flow in branches and run outs closer to the air handler. Similarly, a reducing trunk system reduces the cross-sectional area of the trunk after every branch duct or run out, but it is the most complex system to design. A properly designed reducing trunk system represents the ultimate in an engineered duct system with each portion of trunk duct specially sized so that the trunk is proportionately reduced after each branch takeoff. The system is well-balanced since each branch is specifically engineered but is more costly than other standard duct systems because of custom nature of design, ductwork and installation. Note this is not to be confused with the reduced extended-plenum system described above.

Effective design of reducing trunk systems requires precise Btu and cubic feet per minute (cfm) determinations for each outlet by a qualified contractor or engineer. The outlet, branch duct and portion of trunk duct to which each branch connects must be accurately sized and designed for the required air flow.

Figure below illustrates that the main trunk duct becomes smaller after each takeoff, ultimately reducing to a single branch duct at the last takeoff.

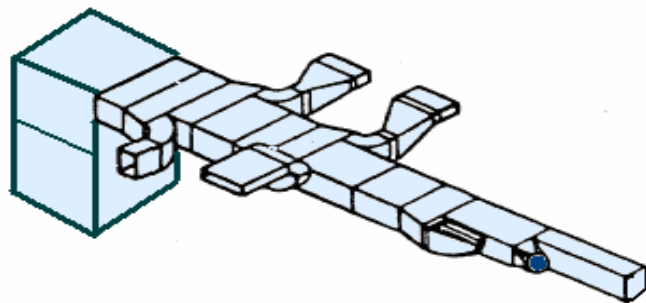

Reducing Trunk Duct System

Since air delivery requirements in a reducing trunk system are predetermined by design, grilles are sometimes used in place of registers to avoid tampering at individual outlets. Proper design of a reducing trunk system requires a well-qualified HVAC contractor or engineer.

6.3 Spider System

A spider system is a more distinct variation of the trunk and branch system. Large supply trunks (usually large-diameter flexible ducts) connect remote mixing boxes to a small, central supply plenum. Smaller branch ducts or run outs take air from the remote mixing boxes to the individual supply outlets. The figure below illustrates this concept.

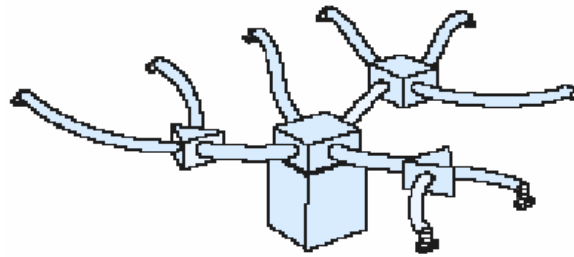

Spider Duct System

6.4 Radial System

In a radial system, there is no trunk duct; branch ducts or run outs; rather individual supply outlets are essentially connected directly to the air handler, usually using a small supply plenum. The short, direct duct runs maximize air flow. The radial system is most adaptable to single-story homes. Traditionally, this system is associated with an air handler that is centrally located so that ducts are arranged in a radial pattern. However, symmetry is not mandatory, and designs using parallel run outs can be designed so that duct runs remain in the conditioned space (e.g., installed above a dropped ceiling). Radial systems typically are used where it is not necessary to conceal ductwork and where the equipment could be centrally located to take best advantage of the system.

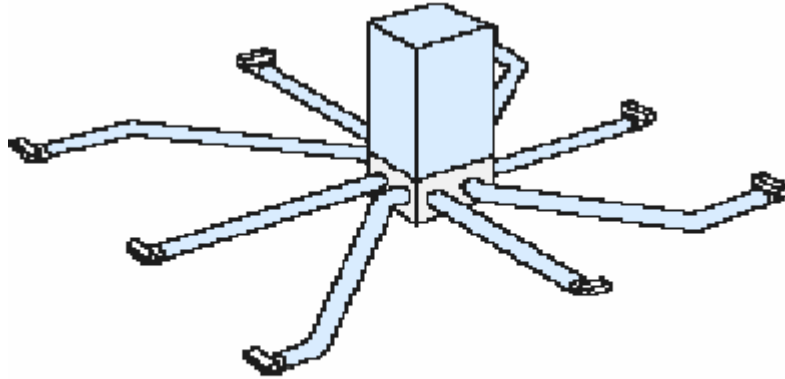

Radial Duct System

This system is practical where the piping runs are located in an attic or crawl space. The radial system is most economical and easiest to install, but is not practical if the air handling unit or furnace cannot be centrally located.

6.5 Perimeter Loop System

A perimeter loop system uses a perimeter duct fed from a central supply plenum using several feeder ducts. This system is typically limited to facilities built on slab in cold climates.

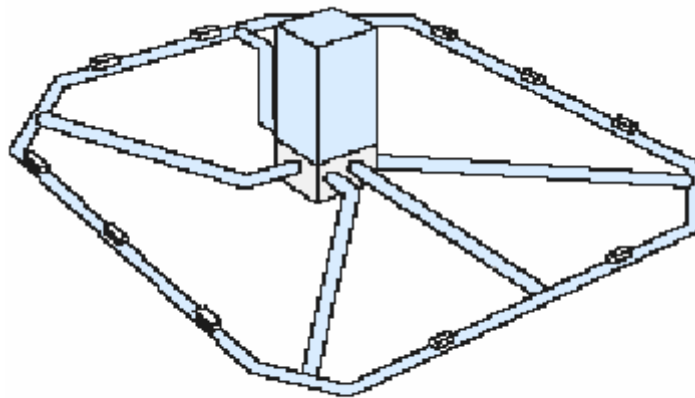

Perimetric Loop System

7.0. RETURN DUCT SYSTEMS

Duct systems should provide balanced supply and return flow in order to maintain a neutral pressure within a conditioned space. Maintaining a neutral indoor air pressure is important to the health, safety, and comfort of occupants, as well as to the energy efficiency. An unbalanced system can draw mold spores, dust, humidity, radon gas, and other contaminants indoors.

7.1 Return Duct Configurations

Air return duct systems can be configured in two ways: 1) Distributed return duct system and 2) Central return duct system. In a distributed return duct system, each room has a return duct that provides a pathway for air to flow back to the air handler. In a central return duct system, or whole-house return, return grilles are located in central locations on each floor, usually close to the air handler. Traditionally, central returns have been less popular than distributed returns because of privacy problems and noise transfer. A correctly installed central return duct system however exhibits none of these issues. Central return duct systems are the better choice in duct system design due to following reasons:

- Central duct systems require less ductwork than a distributed system. When the amount of ductwork is reduced, fewer connections are required, providing a more direct path for air flow. With fewer seams and joints, potential leaks are minimized, and the system is more efficient.
- The system minimizes the surface area of the ductwork, resulting in less energy loss. There's less pressure loss too, since the duct size is larger overall.
- A centralized location also reduces installation time and the cost of materials.

7.2 Maintaining Neutral Pressure

In order to keep supply air from pressurizing closed rooms, transfer grilles or jump ducts are installed to equalize the pressure and allow conditioned air from supply duct to flow evenly back to the central return grille. This is especially important for rooms without return registers.

A transfer grille is a grille that allows air to move from one space to another to alleviate pressure differences. For example, a pressure grille installed above a bedroom door enables air to move between the bedroom and the hallway, regardless of whether the door is open or closed. Transfer grilles can be installed with baffles inside. These baffles work to minimize sound travelling from the hallway, allowing for a more soundproof room. An alternative is to ensure that undercut doors are provided with sufficient free area for face velocities under the door of 100-300 fpm.

Jump ducts are short ducts that run in the attic from the ceiling of a closed room to a ceiling to provide an alternative pathway for air to flow when a door is closed. They're routed through the attic in order to minimize noise transmission in a home. Jump ducts are often less than 6 feet long and connect one room to another. Each end of a jump duct is then connected to a standard return air register vent. Jump ducts are a great way to reduce ductwork. They're often installed in the ceiling and provide pressure balance between bedrooms and main living areas.

8.0. DUCT SIZING

The main goal of designing HVAC duct systems is to use the lowest cost (read smallest) duct sizes that can be used without violating certain sizing constraints. First and operating cost considerations

dictate that duct systems should be designed to operate at the lowest possible static pressure. The most widely used method to size duct is constant friction loss method. The other methods are velocity reduction method and static regain method.

8.1 Constant friction loss method

Duct systems in small buildings are generally sized using the equal friction or modified equal friction method. The equal friction method, as its name implies, is based on maintaining the same pressure drop per unit of duct length (or friction rate) throughout the system (ACCA 1990). The duct size is based on the flow rate through a particular section of duct, and design value for the friction rate. Each section is sized using the design friction rate criterion, and the total pressure drop for each run is simply the sum of the pressure drop of each individual section. The duct sections pressure drop includes straight duct friction loss, pressure losses through fittings such as elbows, takeoffs, and registers and /or diffusers. In the sections entering and leaving the HVAC unit, pressure losses associated with the flow transitions entering the leaving the unit (the system effect) are also included. The unit fan speed is selected to provide the design cfm and produce enough pressure difference to overcome pressure losses in the supply and return branches having the greatest pressure drop. Note that duct systems designed using the equal friction method is not self-balancing. Balancing dampers must be installed in lower pressure loss branches to balance the system.

In duct systems with branches having widely varying pressure losses, the modified equal friction method is used to design systems that are closer in balance (ACCA, 1990). Design friction rates for shorter duct runs are increased in an attempt to design each branch with the same total pressure loss. This method provides a design that is better balanced, but balance dampers must still be installed since it is not possible to provide a truly self balanced system using this method. Also, duct velocities in shorter runs must be checked for noise problems.

Duct size is generally selected using a slide rule or ductulator. The duct section air quantities and design friction rate are matched on the slide rule, and a round duct diameter or several combinations of rectangular duct length and width are displayed. Duct section air velocity is also displayed to check for potential noise problems. Duct dimensions are based on the interior dimensions; if duct liner is used, the thickness of the duct liner must be subtracted. Pressure loss data are based on smooth duct. Adjustment factors must be applied to lined duct, duct board, and flex duct.

Design Values

Principle design variables are the design velocity (chosen for noise control) or the design friction loss (in W. C. per 100 ft). Typical design friction rates are 0.1 in-WC per 100 ft in commercial buildings. Reducing the design friction rate to 0.05 in-WC per 100 ft increases the duct size and costs by 15%, but cuts the portion of the total pressure drop attributable to the ductwork by 50%, and the

overall distribution system pressure drop on the order of 40% when diffuser losses are included. Upsizing the duct can provide fan energy savings on the order of 15% to 20%. To avoid disturbing noise levels - keep maximum velocities within experienced limits:

- Comfort systems - air velocity 800 to 1400 fpm
- Industrial systems - air velocity 1500 to 2400 fpm
- High speed systems - air velocity 2000 to 3600 fpm

If high air velocities of the range are used, ducts can be sized relatively small. But excessive noise and a large total pressure drop necessitating a powerful and noisy fan are almost certain results of downsized duct system. Still, velocity constraints can be varied for individual duct sections so that duct sizes can be selectively minimized without adversely affecting noise considerations. Likewise, the maximum allowable pressure drop per 100 feet of duct can sometimes be increased when it is known that the resulting greater pressure loss is still within the capacity of the fan.

Once the air conditioning system has been traced, sizing of the various sections of the duct must be carried out. In practice, once the velocity in the main duct immediately downstream from the fan has been fixed and once the air capacity is known, the value of the pressure loss in this length of duct can immediately be determined from a device commonly known as "ductulator" or the monographs (see below).

The pressure drop in the air distribution system is obtained by multiplying the total equivalent length of the most unfavorable circuit (usually the one feeding the diffuser furthest away) by the unit pressure loss previously fixed. Since this unit loss is constant for the whole ducting system, the diffusers located near the fan may require the use of throttling air locks so as not to create any irritating noise. A higher-pressure-loss fitting may be desirable if the fitting is located in a branch near a fan or helps provide pressure balancing.

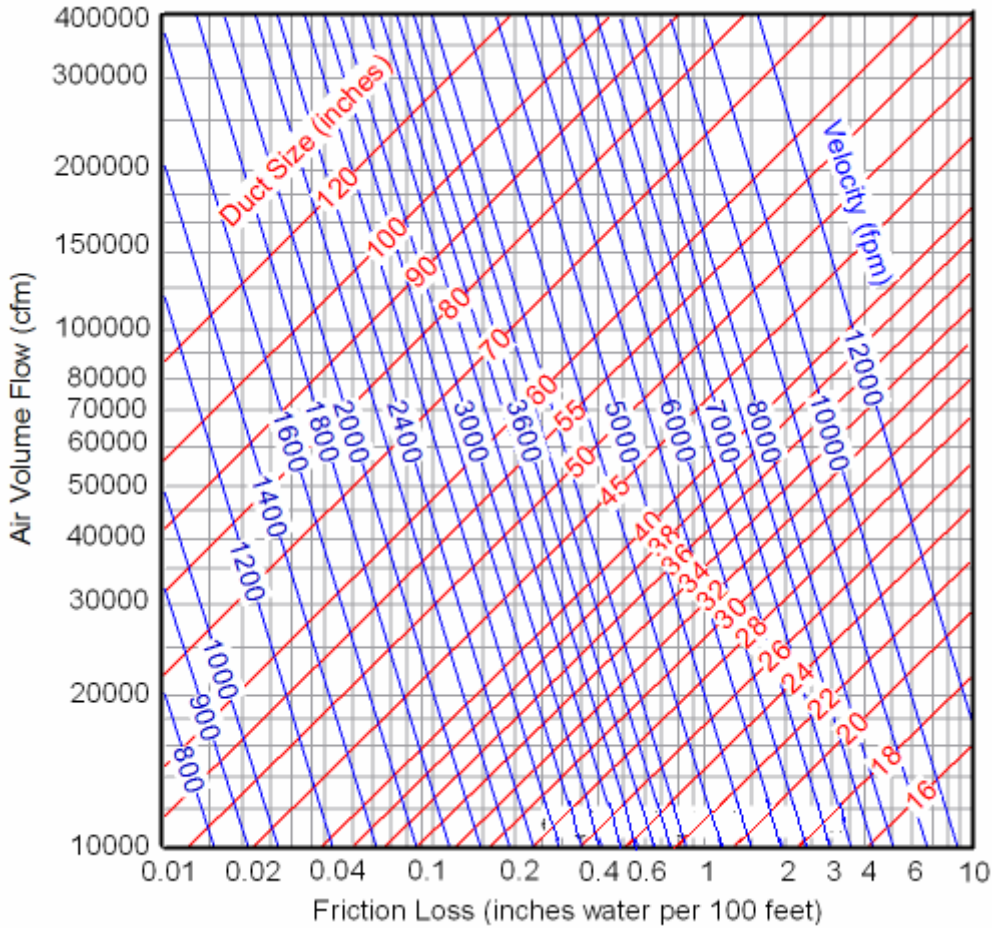

Manual D by ACCA recommends sizing ducts using constant friction method on longest runs, but there is a qualifier. If that design criterion produces an air velocity in any duct that is higher than the manual's velocity limits, then that duct should be resized using the velocity criteria. On the supply side, an inappropriately high air velocity translates into noisy system operation, uncomfortable blasts of air, and unnecessary energy use to create the high CFM. The velocity criteria will always apply unless the friction rate is absurdly low--that is, below about .03" per 100 feet length. This is particularly true for return ducts as the velocity recommended by Manual D for return ducts is 600 feet per minute, with a maximum of 700 feet per minute.

Advantages:

1. The equal friction method is straightforward and easy to use and gives an automatic reduction of the air flow velocities throughout the system. The reduced velocities are in general within the noise limits of the application environment.
2. The advantage of this design method is its simplicity: calculations can be made using simple tables and duct calculations.
3. A design flow, each 100 feet of duct has roughly the same total pressure drop that requires less balancing for symmetrical layouts.

- 4. Automatically reduces air velocities in the direction of airflow. This reduction will decrease the chances of introducing airflow generated noise from high velocities.
- 5. System velocity may be readily checked at any point. This method is most appropriate for constant air volume (CAV) systems.

Limitations:

The method can increase the numbers of reductions compared to other methods, and often a poorer pressure balance in the system require more adjusting dampers. This may increase the system cost compared to other methods.

Equal friction duct design is not recommended for VAV systems and is better suited for CAV systems. In constant volume system, static pressures throughout the duct system can be balanced at design flow using balancing dampers, but are no longer balanced at part load flows. For this reason, equal friction duct designs are better suited for constant volume systems than for VAV systems. *If the equal friction method is used for VAV supply duct design, the terminal units require pressure independent (Pi) control capability to avoid excessive flow rates when duct pressure is high.*

Duct systems designed using the equal friction methods are not flexible and adaptable to future layout changes. In buildings with large areas of open plan space, the main duct size shall be increased for revisions in the future.

8.2 Velocity Reduction Method

The velocity criterion for sizing duct is fairly simple and straightforward.

With this method, the ducts are sized fixing the speed in the duct immediately downstream from the delivery fan and empirically reducing this speed over subsequent duct trunks, normally close to each branch. Velocity limits are commonly used as a surrogate for limiting duct breakout noise. Many argue it is a poor indicator since noise is more likely to result from turbulence than velocity; e.g., a high velocity system with smooth fittings may make less noise than a low velocity system with abrupt fittings. Nevertheless, limiting velocity to limit noise is a common practice. It is important to consult with the project’s acoustical engineer on this issue. Many rules-of-thumb for velocity limits exist depending on the noise criteria of the spaces served and the location of the duct. The typical values are listed in the table below:

Recommended Speed (FPM)

Element	Residential Buildings	Public Buildings, Schools, Theaters	Industrial Buildings

External Air Inlet	500	500	500
Fan Pressing Inlet	1000 - 1600	1300 - 2000	1600 -2400
Main Ducts in occupied spaces	700 - 900	1000 -1300	1200 – 1800
Secondary Ducts	600	600 -900	800 – 1000
Secondary Uprights	500	600 - 700	800
Maximum Speed (FPM)			
Element	Residential Buildings	Public Buildings, Schools, Theaters	Industrial Buildings
External Air Inlet	800	900	1200
Fan Pressing Inlet	1700	1500 - 2200	1700 - 2800
Main Ducts in occupied spaces	800 - 1200	1100 - 1600	1300 - 2300
Secondary Ducts	700 - 1000	800 - 1300	1000 - 1800
Secondary Uprights	600 - 800	800 - 1200	1000 - 1600
Mechanical rooms or shafts	1600	2500	3000

Velocity in duct can be expressed as

$$v = Q * f / A = 144 * Q * f / a * b$$

Where

Q = Air volume in cubic feet per minute

v = air velocity (ft/min)

A = area of duct (square feet) for rectangular duct, A = a x b

a = length of duct side (inches)

b = length of other duct side (inches)

f = Friction Allowance

- Frictional Allowance for round ducts = 1
- Frictional Allowance for square ducts = 1.05 to 1.10
- Frictional Allowance for rectangular ducts = 1.25

8.3 Static Regain Method

This method refers to increase or regain of static pressure in the ductwork when the air velocity decreases. The Static Regain method of duct sizing is based on Bernoulli's equation, which states that when a reduction of velocities takes place, a conversion of dynamic pressure into static pressure occurs.

With this method, the air speed in the duct is reduced near each branch or diffuser so that the dynamic pressure conversion obtained exactly balances the pressure drop of the air in the trunk of the next duct. This means there is the same static pressure near all the branches and all the diffusers, thereby obtaining an intrinsically balanced air distribution system without having to use throttling devices.

Compared to the two previous methods, this method usually involves a larger surface area of the panels, but lower electric fan power and easier balancing of the plant.

For complex plants, it may be advisable to apply two methods simultaneously; the constant pressure loss method for sizing the main trunk, with insertion of adjustment air locks on the branches; the static pressure recovery method for sizing the branches fitted with terminals to obtain the same operating pressure in the latter.

Advantages:

1. Static regain calculations help to adjust duct size to obtain equal static pressure and correct air quantity at each outlet.
2. Duct velocities are systematically reduced, allowing a large portion of the velocity pressure to convert to static pressure, which offsets the friction loss in the succeeding section of duct. According to the SMACNA's HVAC Systems-- Duct Design manual, the static regain, which is assumed at 75 percent for the average duct system, could be as high as 90 percent under ideal conditions.
3. Duct system will stay in balance because the losses and gains are proportional to a function of the velocities. Therefore, it is an excellent method for designing variable air volume systems.

Disadvantage:

Oversized ducts can occur at the ends of long branches.

9.0. DUCT CONSTRUCTION & REINFORCEMENT

Duct walls, transverse joints, and reinforcements at or between joints and supports make up the basic elements of duct construction. Each size in a pressure class has a minimum duct wall thickness and a minimum specification for joints, reinforcements, etc. Depending on the duct pressure and type, joints and seams are made in different ways. *Figure below* shows the various types of slip joints made for a low-pressure rectangular duct system.

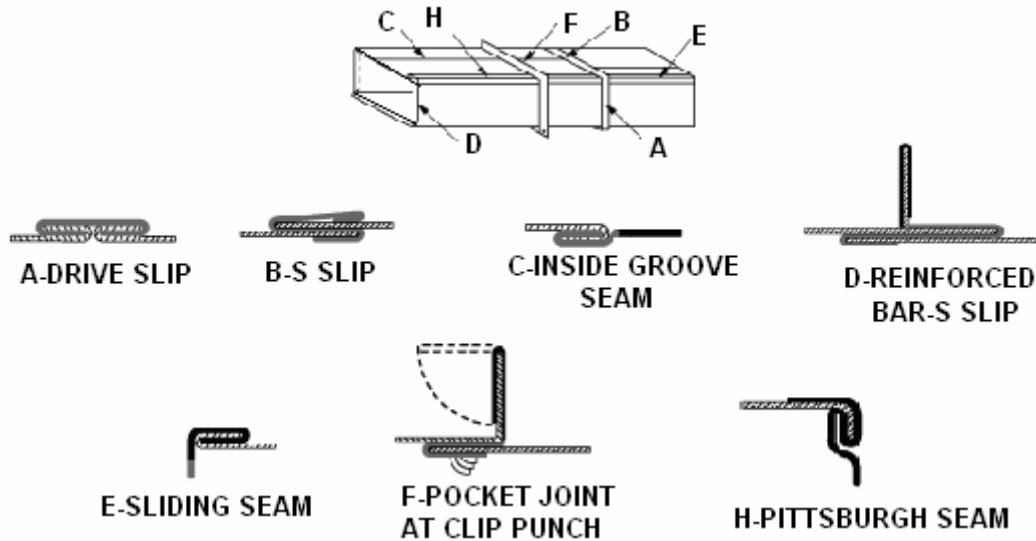

When round duct is used, the joints and seams are typically joined with sheet metal screws and then sealed. Refer to SMACNA's HVAC Duct Construction Standards for further details.

9.1 Duct Sheet Metal Thickness

The greater of the duct's dimension is the one that is used to determine the gage of the sheet metal for all sides.

Rectangular Duct			Round Duct		
Greater Dimension	Galvanized Steel (gauge)	Aluminum (gauge)	Diameter	Galvanized Steel (gauge)	Aluminum (gauge)
Up to 30 inch	24	22	Up to 8 inch	24	22
31 – 60 inches	22	20	9 – 24 inches	22	20
61 – 90 inches	20	18	25 – 48	20	18

Rectangular Duct			Round Duct		
Greater Dimension	Galvanized Steel (gauge)	Aluminum (gauge)	Diameter	Galvanized Steel (gauge)	Aluminum (gauge)
			inches		
91 inches and above	18	16	49 – 72 inches	18	16

Note that lower the gauge, thicker will be the sheet metal. For galvanized steel

24 gauge = 1.156 lb/sq-ft

22 gauge = 1.406 lb/sq-ft

20 gauge = 1.656 lb/sq-ft

18 gauge = 2.156 lb/sq-ft

Cost of galvanized steel = \$ 10 per lb (year 2004 - 05)

9.2 Duct Hanger Spacing

Maximum ductwork hanger spacing:

SMACNA Minimum Requirements:

- Horizontal: 8 feet maximum
- Vertical: 16 feet and at each floor

Good Engineering Practices:

- Horizontal Ducts less than 4 square feet: 8 feet maximum
- Horizontal Ducts 4 to 10 square feet: 6 feet maximum
- Horizontal Ducts greater than 10 square feet: 4 feet maximum
- Vertical Round Ducts: 12 feet maximum
- Vertical Rectangular Ducts: 10 feet maximum

10.0. RECOMMENDED PRACTICES FOR DUCTING LAYOUT

Air distribution within the space is critical to maintaining space conditions and minimizing sound concerns. The first step in designing an efficient ducting layout is to determine the volume of air required in each zone. The next consideration is to determine the type, number, and location of each outlet for the space, and the air volume required for each outlet. Some general guidelines are presented below to help designers develop a good design that provides a reasonable, if not optimum, balance between first costs and operating costs.

10.1 Zoning

Zoning is a practice of dividing a building into smaller areas (zones), thereby providing the opportunity to control comfort levels in each zone. Zoning influence the way ducting is routed and often require multiple ducts, each feeding a respective zone. For example, in single story residential it is normal for the system to be a single zone. In some instances, two story dwellings have single HVAC zones but it is difficult to maintain optimum comfort from the first floor to the second floor for obvious reasons. Because warm air rises the upstairs of the dwelling will always be warm and the downstairs will always be cooler. A two story dwelling will keep each floor comfortable by HVAC zoning the systems or by having two separate systems, one for upstairs and one for downstairs. In large commercial HVAC systems, VAV (Variable Air Volume) systems are a more sophisticated form of zoning. After determining the zones for the building, a preliminary layout of the ductwork is drawn. Preliminary duct layout can be drawn either in single-line (non-detailed) or double line technique.

Proper zoning provides greater comfort, reduces energy use due to over-conditioning, and reduces equipment wear. In some cases, separating central and special use zones can eliminate the need for heating equipment in these areas.

1. When possible, provide separate zones for areas with different occupancies and demand profiles. This has a higher initial cost, but will provide greater comfort and may help avoid retrofits.
2. Group areas with similar demand profiles together into common zones. Factors affecting demand profile are exposure to exterior surfaces (especially windows), orientation with respect to the sun, equipment and people loading, activities, and ventilation requirements.
3. Isolate areas with specific conditioning requirements and provide separate zoning or air handling units, if necessary. Examples of this are computer rooms, exercise rooms, chemical storage, and clean rooms.
4. For larger systems, variable air volume is recommended.

10.2 Selecting Outlets and Intakes for Supply, Return and Extract

The number one concern in evaluating the air distribution in a space is the comfort of the occupants. The normal air velocity used for comfortable air distribution is 50 fpm while the acceptable range is from 25 to 75 fpm. Outlets should be located to distribute the air as uniformly as possible throughout the room. Stagnant air is eliminated by an effective use of entrainment, which is the process by which the velocity of the air discharged from an outlet induces movement of the air already present in the room and blends the two. The process is known as aspiration*.

In selecting outlets, keep in mind that cool air tends to drop away from the outlet, and warm air tends to rise to the ceiling. Select air outlets that provide acceptable air distribution for both cool and warm air.

The following order is followed for supply outlet location and selection:

- 1) Determine room supply air quantity from heating and cooling load calculations and design ventilation requirements.
- 2) Select type and quantity of outlets for each room and evaluate:
 - a) Outlet cfm
 - b) Outlet throw pattern
 - c) Building structural characteristics
 - d) Aesthetic architectural requirements
 - e) Integration with other building systems, i.e. lighting, ceiling grids, partitions, etc.
- 3) Locate outlets to provide uniform room temperature using as uniform an air distribution pattern as possible.
- 4) Select proper outlet size from manufacturer's catalogue data considering:
 - a) Outlet cfm
 - b) Discharge velocity (throw) and Aspiration ratio*
 - c) Distribution pattern
 - d) Total pressure loss
 - e) Sound level.

Tables below provide a general guide for the proper selection of outlets based on design requirements of cfm per square foot and air changes per hour (SMACNA 1990).

Type of Outlet	Floor Space		Approximate maximum air changes/hour for 10 feet (3m) ceiling
	CFM per Feet	Sq L/s per Sq-m	
Grilles & Registers	0.6 to 1.2	3 to 6	7
Slot Diffusers	0.8 to 2.0	4 to 10	12

Type of Outlet	Floor Space		Approximate maximum air changes/hour for 10 feet (3m) ceiling
	CFM per Feet	Sq L/s per Sq-m	
Perforated Panel	0.9 to 3.0	5 to 15	18
Ceiling Diffuser	0.9 to 5.0	5 to 25	30
Perforated Ceiling	1.0 to 10.0	5 to 50	60

***Aspiration:** As supply air leaves a supply register, it has a certain volume of flow rate expressed in CFM; this is called primary air. As soon as this air leaves the outlet, it begins to attract air already existing in the room. This room air, called the secondary air, joins the primary air and is carried along with it. The moving air stream has now a much greater volume by the time it reaches the end of its throw. This total volume, divided by the primary air volume is called the aspiration ratio. *A high aspiration ratio is good, because it means that a greater quantity of air is kept in motion, with less chance of stagnation in parts of the room and with less chance of temperature stratification within the room.*

10.3 Location of supply, return and exhaust registers

A supply outlet is positioned to mix conditioned air with room air and is responsible for most of the air movement within a room. Following key point should be noted:

1. In cold climates, perimeter floor outlets that blanket portions of the exterior wall (usually windows) with supply air are generally preferred.
2. In hot climates, ceiling diffusers or high wall outlets that discharge air parallel to the ceiling are typically installed.
3. In moderate climates, outlet location is less critical. Outlet locations near interior walls can significantly reduce duct lengths (decreasing costs), thermal losses (if ducts are located outside the conditioned space) and blower requirements.
4. To prevent supply air from being swept directly up by kitchen, bathroom, or other exhaust fans, the distance between supply registers and exhaust vents should be kept as large as possible.

5. The location of the return register has only a secondary effect on room air motion. However, returns can help defeat stratification and improve mixing of room air if they are placed high when cooling is the dominant space-conditioning need and low when heating is dominant.
6. In multi-story buildings with both heating and cooling, upper-level returns should be placed high and lower-level returns should be placed low. Otherwise, the location of the return register can be determined by what will minimize duct runs, improve air circulation and mixing of supply air, and impact other considerations such as aesthetics.
7. Return air inlets are generally located so that the room air returned is the greatest temperature difference from that being supplied to the room. A return air inlet that is located directly in the primary air stream of the supply outlet will short circuit the supply air back into the return without mixing with room air.
8. Special situations that require careful attention by the designer are the location of return and exhaust inlets in bars, kitchens, lavatories, dining rooms, club rooms, etc. These normally should be located near or at the ceiling level to collect the warm air "build-up," odors, smoke, and fumes.

10.4 Mechanical Rooms

Mechanical rooms are required for locating the air handler unit (AHU) and the associated auxiliaries such as refrigerant/chilled water piping, ductwork and fittings, acoustic silencers, electrical & control panels etc. Space requirements of mechanical and electrical equipment rooms shall be based upon the layout of equipment drawn to scale within each room. Space shall be provided around all HVAC system equipment as recommended by the manufacturer and in compliance with local code requirements for routine maintenance. Access doors or panels should be provided in ventilation equipment, ductwork and plenums as required for in-site inspection and cleaning. Main mechanical equipment rooms generally shall have clear ceiling heights of not less than 3.6m (12 feet).

The ductwork within the mechanical room has the biggest cross section because here the ductwork carries the maximum volume of air. A good amount of planning is required in routing of ducts, which in turn is dependent on the type of air handler (horizontal or vertical discharge), number of units etc. Ideally the AHU capacity should be restricted below 2500CFM.

10.5 Duct Routing & Layout

All duct systems are designed around one simple principle: deliver the air from the central air handling unit to the air terminals in the simplest direct route possible while following the line of maximum duct clearance. Following this principle usually results in one of three basic symmetrical layouts for the main and trunk ducts:

- a. The spine layout
- b. The H-pattern layout
- c. The loop or doughnut layout

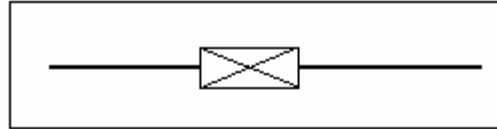

SPINE DUCT LAYOUT

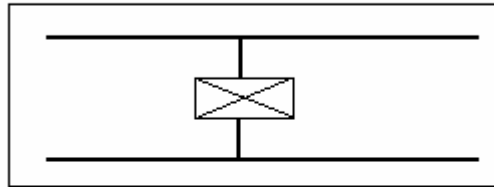

H- PATTERN LAYOUT

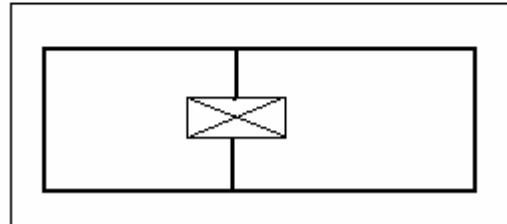

LOOP DUCT LAYOUT

The H pattern is the most popular method and is seen in most buildings. The spine method is likely to be found in narrow buildings with a width of 50' to 75'. The loop layout is found in larger multi-story buildings. The loop is a modification of the H-type design and results in smooth, even changes in duct static pressure at the supply fan, particularly on VAV type systems.

Once the routing has been established, definitive design can start. Go straight! This is the most important rule of all. The straighter the duct system, the lower both energy and first costs will be. From an energy perspective, air “wants” to go straight and will lose energy if you make it bend. From a cost perspective, straight duct costs less than fittings. Fittings are expensive because they must be hand assembled even if the pieces are automatically cut by plasma cutters. So, when laying out a system, try to reduce the number of bends and turns to an absolute minimum.

The trunk ducts are usually located above corridors in the cavity above the ceiling to minimize noise transmission to the conditioned zones, and allow easy access without disturbing the building occupants. Ducts that connect the trunk ducts to the air diffusers are called runout ducts. Runout ducts extend outward from the trunk ducts for distances up to 25'. Thus, a trunk duct with runout ducts on either side will cover a 50' path through the building. For constant volume systems, the

runout ducts are made of sheet metal and come within 6' of the air diffusers. The final 6' are usually made of flexible material to facilitate alignment and to minimize noise.

Good duct design provides a smooth transition from the central air handler fan discharge to the initial section of the main duct. Not providing this will result in excessive loss of fan pressure and lack of air at the control zones. This is where a lot of jobs run into trouble, particularly with small packaged units that have limited fan pressure capability to begin with.

Duct routing is often limited by building constraints. Most restrictive is the clearance between the top of the ceiling system and the underside of the roof (or next floor above). The minimum clearance between the bottom of the duct and a finished ceiling should be at least 150 mm (6") to account for light fixtures, communication devices, sprinkler piping and thickness of ceiling. Because ducting is installed prior to ceiling installation, normal practice is to determine the height of the duct's lowest feature in relation to the finished floor in order to maintain adequate clearances. This height needs to be specified whenever it is critical to a layout.

10.6 Duct Locations

Ducts placed within conditioned spaces are more efficient than those placed in unconditioned spaces. If located within conditioned space, conductive and radiative losses, leakage losses, and equipment cabinet losses are reduced or regained into the building space. Also, ducts located inside the conditioned space need minimal insulation (in hot and humid climates), if any at all. The cost of moving ducts into the conditioned space can be offset by smaller heating and cooling equipment, smaller and less duct work, reduced duct insulation, and lower operating costs. There are several methods for locating ducts inside the conditioned space.

1. Place the ducts in a furred-down chase below the ceiling (e.g., dropped ceiling in a hallway), a chase furred-up in the attic, or other such chases. These chases must be specially constructed, air-sealed, and insulated to ensure they are not connected to unconditioned spaces.
2. Locate ducts between the floors of a multi-story home (run through the floor trusses or joists). The exterior walls of these floor cavities must be insulated and sealed to ensure they are within the conditioned space. Holes in the cavity for wiring, plumbing, etc., must be sealed to prevent air exchange with unconditioned spaces.
3. Locate ducts in a specially-constructed sealed and insulated crawlspace (where the walls of the crawlspace are insulated rather than the ceiling).
4. Space is at a premium in the shafts that allow pipes and ducts to travel vertically through a building. Chases tend to run in the core of a building, which often contains many of the structural elements of a building's seismic load bearing system. The structural shear walls

and heavy beams in this area, combined with the architectural desirability of high ceilings, can lead to a very narrow duct path out of the chase, which can push duct velocities even higher than they were in the riser duct. This velocity increase triggers a pressure drop precisely where it is least desirable: at the transition fittings and dampers that are required to tap the riser and exit the chase. Careful detailing is required at these points to assure that the fittings minimize system pressure drops.

5. If possible, locate new ductwork and relocate old ductwork within the conditioned envelope. This means avoiding exterior walls, garages, crawlspaces, and attics. If it is not feasible to locate ductwork within conditioned space, the ducts should be properly sealed and insulated. Consideration must also be given to:
 - Additional space required beyond bare sheet metal sizes for reinforcing, circumferential joints, and hangers.
 - External insulation or duct liner.
 - Clearance for piping, conduit, light fixtures, etc.
 - Clearance for removal of ceiling tile.
 - Space requirement for air terminals, mixing boxes, pressure reducing boxes, fire and smoke dampers, reheat coils, etc.

10.7 Duct Fittings and Transitions

1. Duct Sizes and reductions - Accepted methods of duct design usually indicate a reduction in duct area after each terminal and/or branch takeoff. However, unless a reduction of two inches can be made, the original duct size should be maintained. Savings of as much as 25 percent in installed cost can be made by running the duct at the same size for several terminals. Generally, all duct sizes should have even dimensions.
2. Transitions - Transitions are usually placed in a trunk or branch duct following a tap-in or branch because the airflow rate is reduced. An expanding transition at the fan discharge is usually used to reduce the main trunk velocity and its associated pressure drop. The least expensive transition maintains three sides straight while changing the fourth side. The changing of two or more sides presents both a layout and an installation challenge. Ideally, the slope of transition shall be 8 degrees to a maximum of 14 degrees. When the duct area is increased, the slope is not to exceed eight degrees.
3. Use standard length straight ducts. Minimize both the number of transitions and joints since the sheet metal is not as expensive as the labor to connect pieces together and seal the joints. Straight, standard length ducts are relatively inexpensive since duct machines, such as coil lines for rectangular ducts, automatically produce duct sections usually 5 feet long.

Any rectangular duct that is not a standard length is technically a fitting since it cannot be made by the coil line. While spiral round duct can be virtually any length, it is commonly cut to 20 feet to fit in standard trucks. Oval duct standard lengths vary depending on the fabricator but manufactured ducts are typically 12 feet long. It is not uncommon for an inexperienced designer to include too many duct size reductions with false impression that reducing duct sizes will reduce costs. (Refer figures below)

Examples of Poor and Better Duct Design

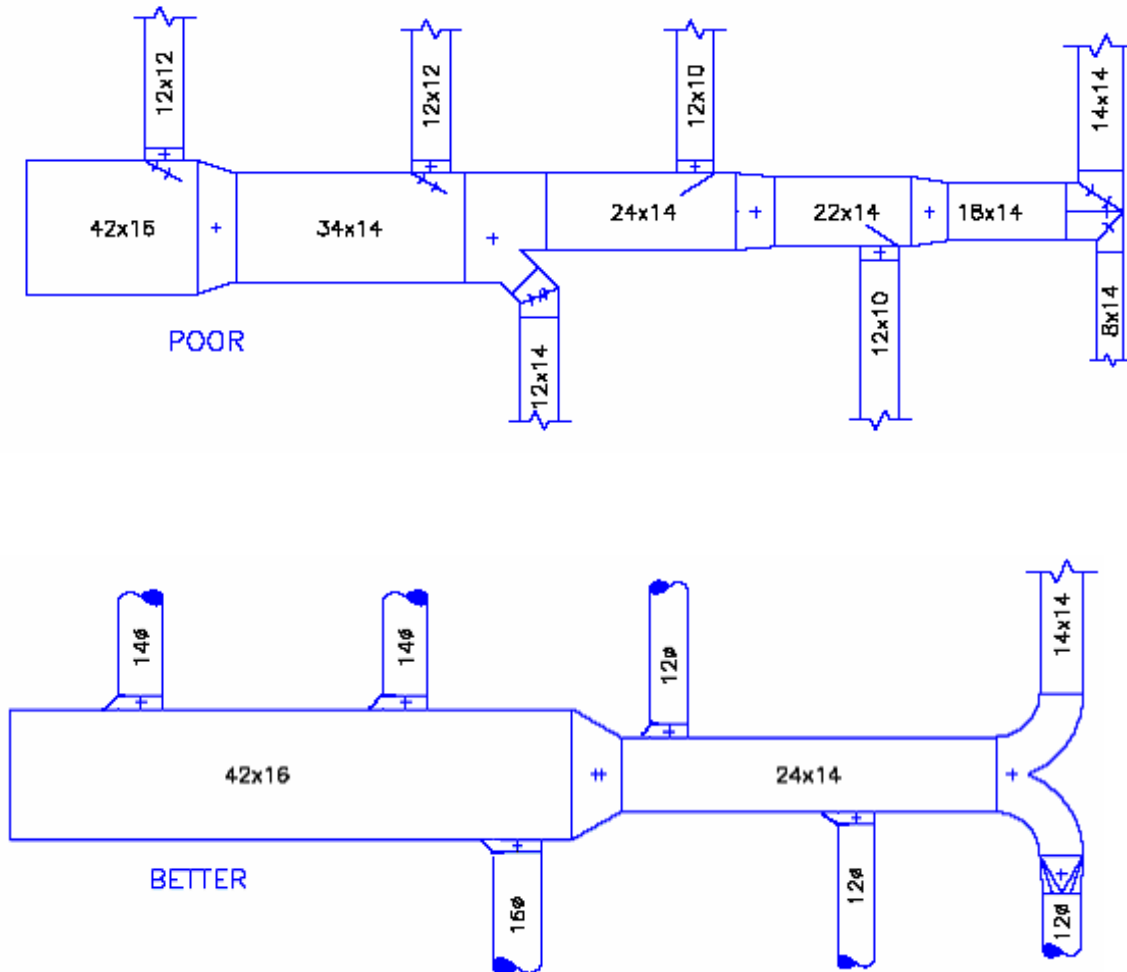

4. Dynamic loss - Dynamic losses occur whenever an air stream makes turns, diverges, converges, narrows, widens, enters, exits, or passes dampers, gates, orifices, coils, filters, or sound attenuators. Devices to reduce this dynamic loss include splitter dampers, extractors, scoops, cones, elbows, and 45° and radius tap-ins. Listed in order of improving performance;
- A 45° tap in is both economical and efficient
 - A basic straight 90° take off falls in the middle of the list
 - Splitter dampers, extractors, and scoops are counterproductive

5. **Elbows** - A variety of elbows are available for rectangular duct system. Elbow types range from mitred to long radius. Long radius elbows are most efficient. An elbow with a centreline radius (r/D or r/W) of 1.5 is very efficient and should be used in cases where duct air velocity is 2,500 fpm or higher. A standard radius elbow (r/D of 1.0) is more economical and only slightly less efficient; it is generally preferred. Short radius elbows are those with an inside throat radius less than the turning width of the duct, but in no case may this throat radius be less than 3 inches. To improve the efficiency of short radius elbows splitter vanes should be provided as follows:
 - A single splitter vane should be provided in short radius elbows with a turning width of 12 inches or less.
 - Two splitter vanes should be provided in short radius elbows with a turning width of 12 to 24 inches.
 - Three splitter vanes should be provided in short radius elbows with a turning width of over 24 inches.
6. Use radius elbows rather than square elbows with turning vanes whenever space allows. Except for very large ducts (those whose shape cannot be cut on a 5-foot wide plasma cutter), full radius elbows will cost less than square elbows with turning vanes, yet they have similar pressure drop and much improved acoustic properties.
7. The first elbow in the ductwork leaving the unit should be no closer than 2 feet from the unit, to minimize resistance and noise.
8. Turning vanes generate some turbulence, which can be noisy at high velocities. On medium and high velocity systems, where a full radius elbow cannot fit, a part-radius elbow with one or more splitters should be used. The splitters essentially convert the duct into nested full radius elbows. This design will have the lowest pressure drop and produce the least noise. Turning vanes should only be used on low velocity systems where radius elbows will not fit. Turning vanes should be single width, not airfoil shaped. Intuitively, airfoil vanes would seem to offer better performance but SMACNA and ASHRAE test data show that they have higher pressure drop as well as higher cost.
9. VAV box inlets should be all sheet metal; do not use flex duct. This will reduce pressure drop because the friction rate of VAV inlet ducts is very high when sized at the box inlet size. It also will ensure smooth inlets to the VAV box velocity pressure sensor, improving airflow measurement accuracy, and reduce breakout noise from the VAV damper (flex duct is virtually transparent to noise).
10. Use either conical or 45° taps at VAV box connections to medium pressure duct mains. Taps in low velocity mains to air outlets will have a low-pressure drop no matter how they

are designed. Use of conical taps in these situations is not justified because the energy savings are small.

11. Inexpensive straight 90° taps (e.g., spin-ins) can be used for round ducts and 45° saddle taps are appropriate for rectangular ducts. Taps with extractors or splitter dampers should be avoided. They are expensive; they generate noise; and most importantly, they cause an increase in the pressure drop of the duct main.
12. Install radius or section elbows at > 45-degree turns. Install turning vanes in supply ducts that turn immediately below a roof penetration. Use vanes with airfoil shape to reduce pressure drop in corners.
13. Dampers – A typical HVAC system contains numerous dampers designed to restrict or stop airflow. These include flow-control, balancing, economizer, back-draft, face and bypass and splitter dampers. Sufficient balancing dampers should be included in the design stage in order to achieve proper balancing and ensuring flexibility of later modification.
 - Opposed blade dampers, are effective only through the center one-third of the 90° travel. At low angles, their dampening effect is negligible, and at high angles, flow rates change too rapidly compared to the angular displacement or travel of the damper. In practice, avoid opposed-blade dampers. These dampers cannot be relied upon to take more than ¼ - ½ closure without noise. For air balancing, provide accessible volume dampers near the branch take-off.
 - Terminal dampers such as those used in registers and diffusers are not to be considered in branch balancing as they are meant to be used for fine adjustment only and would normally be in an almost fully open position to prevent noise generation. Branch dampers should be provided for this purpose. The following guidelines may be used as an aid in locating balancing dampers.
 - In short branches where the required pressure drop is 0.125 inches-wg or higher, a balancing damper is necessary.
 - Where one or more branches are in parallel each branch should have a balancing damper.
 - Any branch where the duct run penetrates a floor and any branch close to a unit discharge.
 - Avoid opposed-blade dampers. These dampers cannot be relied upon to take more than ¼ - ½ closures without noise. For air balancing, provide accessible volume dampers near the branch take-off. The rule of thumb for splitter dampers is: never use them. Another device will always work better. Their biggest problem is a ripple effect on system balance if the splitter moves.

- Dampers must be installed in places where airflow needs to be controlled and/or blocked. Dampers located directly behind an outlet tend to be noisy. A better location is in the final branch near the connection to the trunk duct. Wherever a balancing or volume damper is located, it should be accessible.

(Refer to easternindustries.com brochures for details on the type of fittings)

10.8 Aspect Ratio

The aspect ratio is the ratio of the long side to the short side of a duct. This ratio is an important factor to be considered in the initial design. Increasing the aspect ratio increases both the installed cost and the operating cost of the system. A rectangular duct with an aspect ratio closer to ONE has lower frictional resistance and will use lowest sheet metal.

Example:

Say the main trunk of the duct requires cross-sectional area of 4 sq-ft and is 100 ft long. The duct can be fabricated as 2' x 2' or 1' x 4' dimensions.

In first case 2' x 2', the perimeter = 8 ft and total sheet metal required is 8 x 100 = 800 sq-ft

In second case 1' x 4', the perimeter = 10 ft and total sheet metal required is 10 x 100 = 1000 sq-ft

As the aspect ratio increases from 1: 1 to 1: 4, the surface area and insulation requirements increase 25% percent. Other benefits of low aspect ration include low friction drop, low weight of metal, lower insulation and installation costs.

10.9 Standard Duct Sizes

All standard air conditioners move 400 cubic feet of air per minute per ton or 12,000 BTUs of air conditioning. One ton equals the heat extraction rate of 2,000 BTUH. One BTU is the measurement of heat. It takes one BTU to raise the temperature of water in degree Fahrenheit.

Knowing this we then first need to determine how the duct system is going to be sized. Here are some sizes for supply duct that can be used. Use larger sizing for return air ducting.

a.	100 CFM = 6" round	5x6"	4x8"	
b.	200 CFM = 8" round	6x8"	4x12"	½ ton
c.	300 CFM = 9" round	10x7"	5x14"	¾ ton
d.	400 CFM = 10" round	8x10"	6x14"	1 ton
e.	600 CFM = 12" round	10x12"	8x14"	1-1/2 tons
f.	800 CFM = 13" round	10x14"	8x18"	2 tons
g.	1000 CFM = 14" round	10x16"	12x14"	2-1/2 tons
h.	1200 CFM = 16" round	10x20"	12x16"	3 tons
i.	1400 CFM = 6" round	12x18"	10x20"	3-1/2 tons
j.	1600 CFM = 18" round	14x16"	12x20"	4 tons

k. 2000 CFM = 18" round 12x25" 16x17" 5 tons

11.0. DUCTWORK DESIGN CONSIDERATIONS

11.1 Duct Frictional Resistance

Any type of duct system offers frictional resistance to the movement of supply air. The frictional resistance of a supply duct varies in proportion to the square of the ratio of the velocity at two different velocities, and the fan power varies as the cube of this ratio. If a supply duct, for example, is carrying 5000 CFM of air at 1000 FPM, and a second supply duct is carrying the same quantity of air at 2000 FPM, the frictional resistance of the second duct per foot of duct length will be four times higher than that of the first duct: $(2000/1000)^2$; and the power required to overcome this frictional resistance will be eight times as much: $(2000/1000)^3$.

The AHU fan must develop a pressure equivalent to the frictional resistance of the ductwork (and also overcome the resistance of air control dampers, cooling coils, heating coils, filters, diffusers, sound attenuation equipment, turning vanes etc.). This pressure is measured in terms of inches of water. Total Pressure, TP, is related to the Energy in the Air Stream, and is equal to:

Total Pressure = Static Pressure + Velocity Pressure

1. Static pressure is the outward push of air against duct surfaces as a result of the compressive force applied by the fan. Mathematically, static pressure is the difference between the absolute pressure at a point in an air stream or a pressurized chamber and the absolute pressure at ambient temperature. This is positive when the pressure at that point is above ambient pressure, and negative when below. It acts equally in all directions and is independent of velocity.
2. Velocity pressure is the directional thrust of supply air due to its velocity. It is equal to the product of air density and the square of the velocity divided by 2, and is sometimes known as the velocity head or dynamic pressure. [Velocity pressure = $(\text{Density}) \times (\text{Velocity})^2 / 2$]

A decrease in duct size increases velocity pressure and decreases static pressure; an increase in duct size decreases velocity pressure, increases static pressure. This means that at any point along a duct, the total pressure decreases in the direction of the movement due to the conversion of mechanical energy to heat caused by friction, whereas the static and dynamic pressure can be transferred and therefore one or the other can increase or decrease in the direction of movement itself.

Ductwork Pressure Drop

The duct designer needs to know what the total pressure loss is for a duct run in order to select the proper size fan. The static pressure at the fan outlet must be equal to the resistance of the duct system. The pressure losses of the air during its movement inside the ducts are of two types:

1. Friction Losses – occur due to fluid viscosity and turbulence in the flow through the ductwork and occur along the entire length of the ductwork. The moving air is subjected to a certain amount of resistance which inevitably turns into a load loss. This depends on
 - a. The nature and physical state of the air
 - b. Average speed
 - c. Duct dimensions
 - d. Roughness of the material
 - e. Length of the duct

For all constant-area straight duct sections, the static pressure losses are equivalent to the total pressure losses.

2. Dynamic or turbulence losses result from flow disturbances caused by fittings that change the airflow direction or area. The pressure losses increase more rapidly in the smaller cross-sectional area ducts. When duct cross-sectional areas are reduced abruptly, both the velocity and velocity pressure increase in the direction of airflow. The resistance of a ventilating system is caused by:
 - a. The loss of energy at the point of entry of the air due to a sudden increase in air velocity from practically zero to the velocity along the duct. Keep air velocity at entry around 500 FPM or less.
 - b. The friction between the air and the inside surface of the duct. Keep duct velocities low – about 500 FPM for general use.
 - c. Changes of cross-sectional area of duct, where there are expansions and contractions, or changes of shape (say from square to oblong section). Expansions, contractions, and changes of size or shape should be made by gradual taper sections, not abruptly.
 - d. Changes of direction, such as bends and Tee-junctions are large wasters of energy. Changes of direction should be by easy bends and well-rounded corners, not by sharp elbows, unless fitted with guide vanes (expensive).
 - e. Auxiliary items, such as grilles, louvers, filters, heaters. These items should be large enough to keep air velocities through them down to a reasonable level, consistent with the velocity in the main duct.

Total Pressure Loss

Pressure loss is the loss of total pressure in a duct or fitting. There are three important observations that describe the benefits of using total pressure for duct calculation and testing rather than using only static pressure:

- 1) Only total pressure in ductwork always drops in the direction of flow. Static or dynamic pressures alone do not follow this rule.
- 2) The measurement of the energy level in an air stream is uniquely represented by total pressure only. The pressure losses in a duct are represented by the combined potential and kinetic energy transformation, i.e., the loss of total pressure.
- 3) The fan energy increases both static and dynamic pressure. Fan ratings based only on static pressure are incorrect.

11.2 Duct Equivalent Length

The fittings (elbows, tees, branch connections, etc.) and accessories (dampers, extractors, etc.) in the ductwork offer additional frictional resistance. An additional length has to be added to the actual measured length of the ductwork to take care of the resistance offered by these items to supply air. This additional length is called equivalent length, and the sum of actual measured length and equivalent length is known as total equivalent length (TEL).

$$TEL = L + (C * L)$$

Where

- L = actual measured length
- C = a coefficient of duct system complexity (0.4 for simple duct systems, 1 for very complex duct systems).

Example: The actual length of the longest duct run from the AHU to the furthest supply register in a building is calculated to be 180 feet. If the coefficient of duct system complexity were 0.5, what would be the total equivalent length of the duct run? ----- Answer 270 ft

A shorter total effective duct length (straight run length plus fitting equivalent length) will result in lower pressure losses and lower operating pressure.

11.3 Ductwork System Effect

The heart of the HVAC system is the fan. Improper fan design or installation can cause serious degradation of performance because of "system effects." The Air Movement and Control Association (AMCA) define system effect as "a pressure loss which recognizes the effect of fan inlet restrictions, fan outlet restrictions, or other conditions influencing fan performance when installed in the system."

System effect factors for connections between fan and duct system are presented in "Fans and Systems" (AMCA, 1973), the ASHRAE Fundamentals Handbook. They appear when inlet and outlet connections cause non-uniform inlet and outlet flow and swirl at the fan inlet.

An engineer designing ductwork should provide uniform straight flow conditions at the fan inlet and outlet. An elbow at a fan's inlet causes turbulence and uneven flow into the fan opening. An elbow at a fan's discharge causes a non-uniform backpressure. An engineer can only estimate how much pressure will be lost as a result of system effects by reviewing the air distribution system design.

System effects are rarely measured during system start-up procedures. They become evident only when not enough air is delivered to the building. Start-up personnel must then speed up the fan by changing pulleys or even increasing the fan's motor size in order to get design air-flow rates.

System effects can be reduced or largely avoided by a few easy precautions for centrifugal fans, as follows:

1. With a free inlet fan (no inlet duct), a minimum of one half the fan wheel diameter, D , clearance should be maintained from the inlet to the wall or structure.
2. If a free inlet is required, the inlet duct can be replaced with an inlet bell which provides a smooth transition to the fan velocity with no loss in total pressure.
3. An elbow entrance to the fan should be at least two times the inlet diameter distance from the flex connector at the fan, $C=0.15$ (remember, the fan entrance is a high-velocity duct).
4. The first elbow in the ducting leaving the unit should be no closer than 2 feet from the unit, to minimize resistance and noise.
5. A 2D cone to the inlet flex (vibration isolator) should be used to decrease friction losses ($C=0.10$).
6. If this 2D inlet cone is attached to a rectangular, vertical duct, its dimensions should be two times the fan's inlet diameter by one half the fan's inlet diameter and extend one diameter past the center line of the fan's inlet.
7. When the air undergoes a large expansion, as in a 'free discharge' into a plenum or the atmosphere, the expansion loss becomes significant. In this case, velocity pressure is reduced to approximately zero, since the area is very large. However, none of this velocity pressure is converted to static pressure; in fact, the static pressure also drops since the expansion is so sudden. Total pressure is equal to static pressure at the discharge, since velocity pressure drops to zero.

8. The constant area of the duct connection eliminates any expansion losses. Expansion losses occur whenever air is forced to expand and slow down into a larger area. This loss is kept to a minimum by using a cone with a diverging angle of 15°.
9. The advantage of using an outlet cone, however, can be seen in the conversion of velocity pressure to usable static pressure. This is referred to as static regain and the result is lower fan BHP for a given static pressure. An additional benefit is reduced duct resistance due to the lower duct velocity.
10. A straight duct for a distance of three to six duct diameters from the fan discharge should be used in order to develop a full dynamic head. Branching and turning sooner causes system effect losses.
11. A fan discharge diffuser should be used before air is released to the atmosphere.
12. If system-effect situations cannot be avoided, their impact on performance should be estimated and added to the calculated system resistance prior to selecting the fan. Ignoring system effects can lead to difficult process performance problems later and most certainly higher operating costs over the life of the cooling system.

11.4 Installation Issues

Energy-efficient installation practices can have a major impact on energy costs. Field studies conducted by the Lawrence Berkeley National Labs show that in light commercial buildings supply duct leakage averages 26 percent of the fan flow. Furthermore, computer simulations demonstrated that in large commercial buildings, 20 percent supply leakage into conditioned space can result in a 60-70 percent increase in [constant volume] fan power corresponding to approximately 1 kWh/yr-ft² of wasted energy. Even duct leakage within conditioned spaces wastes energy by forcing the fan to operate at higher pressures to deliver air to the intended zones.

Because access for repairs is usually limited, poorly installed duct systems (that must later be resealed) can cost more than a proper installation. Energy-efficient installations reduce troubleshooting time, maintenance, repairs, comfort problems, disputes and business interruption, while lowering energy costs.

When installing ductwork:

1. Ductwork should be kept as straight as possible. Any turns, bends or 'S' loops will cause additional pressure loss and reduced airflow.
2. No building cavities shall be used as ductwork, e.g., panning joist or stud cavities.
3. Installation of all heating and cooling ducts and mechanical equipment within the conditioned building envelope.

4. No ductwork should be installed in exterior walls.
5. Install return ducts or transfer grilles in every room having a door except baths, kitchens, closets, pantries, and laundry rooms.

11.5 Ductwork Insulation

Insulate ducts in accordance with the minimum requirements of local codes or Section 6.2.4.2 of *ASHRAE 90.1-19992a*, whichever are more stringent. Insulation is applied to ductwork to enhance thermal performance and prevent condensation and dripping.

Duct thermal performance needs enhancement since air transported through a supply duct is at a temperature different than that of the surroundings. Insulation reduces the rate of thermal loss to those surroundings. Without insulation, the air would need extra heating or cooling in order to arrive at the design supply air temperature.

Ducts may sweat when their surface temperature is below the dewpoint of the surrounding air. This is the same phenomenon that occurs when moisture condenses on a glass filled with a cold beverage in the summer. This can lead to water damage and microbial growth within the building. To prevent this from happening, rectangular supply ducts are typically insulated on the inside. Round and oval type ducts are insulated on the outside due to the cost and difficulty involved in providing inside insulation. Duct insulation eliminates the formation of condensate and consequently prevents rusting and staining.

Since insulated duct costs much more than un-insulated, the recommended air velocity becomes a key factor in optimization. For instance, a higher air velocity reduces duct surface area and thus insulation cost.

Supply air ducts may be left un-insulated if they run exposed through the space being conditioned; this arrangement also reduces system first cost.

Return air ducts only need to be insulated if they pass through environments that adversely affect the return air temperature. Exhaust air ducts normally do not need insulation.

Because of the relatively small temperature differences between supply air ducts and the spaces through which they ductwork are routed, a one-inch-thick fiberglass blanket is almost always sufficient. Insulation should be wrapped around the duct's exterior. Good duct design includes thermal efficiency achieved with adequate insulation and airtight seals. Ducts shall be insulated to an R-Value of R-6.

Duct insulation should have a vapor barrier on the outer surface to prevent moisture in ambient air from passing through the insulation and condensing on the duct surfaces. Condensation will cause the insulation to be saturated with water, destroying its insulating ability and deteriorating the duct

material. A protective cover with a vapor barrier such as an aluminum foil should be included in insulation specifications.

Care must be exercised to protect exterior insulation integrity where insulation comes in contact with hangers, supports, and other structural members. Interior duct insulation (lining) should not be used in laboratory or clean room applications because the insulation tends to entrain microscopic particles into the airflow. In cooling load-dominated areas, ducts located on roofs should be covered with a highly reflective coating.

Special consideration must be given to ducts exposed to weather. Lagging materials or heavy metal covers over the insulation are commonly used to protect ductwork. A life-cycle cost analysis may be necessary to determine optimum insulation thickness when ducts encounter temperature extremes.

Placement of ducts can't always be controlled in the design of most spaces; however, any ill effects can be minimized with good duct insulation.

Duct liner is a specially treated, rigid fiberglass insulation used to line the inside of rectangular metal ductwork. Duct liner is installed with a special adhesive to the inside of ductwork or to flat stock prior to forming. The adhesive may be supplemented with special metal clips at critical points.

- *One-inch thick material is used primarily for thermal protection of ductwork that passes through unconditioned spaces.*
- *One-half-inch thick material is frequently used as acoustical insulation for reducing air and equipment noises.*

Duct Wrap is a fiberglass blanket insulation used on metal ductwork passing through unconditioned spaces. Duct wrap provides better thermal protection than duct liner but is of little benefit acoustically. It is installed by wrapping the outside of the ductwork and taping the joints.

11.6 Ductwork Air Leakage

Duct leakage is always uncontrolled, so it should be avoided. Although leakage may not cause an air distribution system to perform improperly, it drives up operating costs. Even when supply ducts are inside a building's envelope and air leakage goes into a plenum space, leakage diminishes the supply air's effect on control sensors, thus increasing system operation. The duct leakage essentially depends on the method of duct fabrication and of sealing as well as on workmanship and static pressure differential. According to the Fundamentals Handbook, Chapter 32 ASHRAE, 1997, duct leakage can be determined as follows:

$$\text{Leakage} = (\text{Leakage class}) * (\text{Static pressure}) * 0.65$$

Because the amount of duct leakage depends on internal static pressure, lower pressure in a system reduces leakage. For a single straight duct static pressure changes uniformly. However, local resistance causes sudden changes of static pressure. Therefore, in general, static pressure and duct leakage are not equally distributed through a duct's length and should be calculated locally between fittings.

The leakage class reflects the quality of duct construction and sealing method. This class is based on experimental data and ranges from 0 for welded ducts to 110 for rectangular unsealed ducts. The average leakage class for rectangular unsealed ducts is 48.

Selecting appropriate duct construction is an important part of minimizing duct leakage. A specification for duct construction and sealing needs to be determined early in the duct design process. The engineer should specify a leakage class (refer ASHRAE, 1997) to meet the requirements of the system application and local energy conservation code. Project specification should allow appropriate duct leakage and leakage testing following the "HVAC Air Duct Leakage Test Manual" (SMACNA, 1985). Random testing should always be required as part of air balancing. More extensive testing is required if the random testing reveals irregularities.

Using welded or flanged and gasketed duct construction in critical exhaust systems will make ductwork virtually leak free. Leakage Class 3 is achievable by most contractors with some practice and guidance in duct construction and sealing techniques.

Leakage occurs at transverse and longitudinal joints and at connections, e.g. at tees, at Variable Air Volume (VAV) boxes, and at flexible terminal sections. Sealing the duct joints, usually with silicone-based sealant, is a basic method for avoiding the leaks. Duct sealing is recommended whenever electricity cost is greater than \$0.02/kWh and sealing cost is less than \$1.5/m² (\$0.14/ft²). Sealing of ducts is always required for process exhausts.

11.7 Testing Methods and Equipment

Duct testing is the process of using calibrated mechanical equipment to measure the amount of airflow that is lost through the duct system when it is at normal operating pressure. While some joints or seams may have only small leaks, other sections may be completely disconnected. Duct testing can indicate the relative leakiness of the ducts and help determine whether the duct system should be sealed, repaired, or renovated.

There are two main methods of testing.

The *pressurization subtraction method* utilizes a pressurization unit (i.e. a high powered fan set up in a doorway and connected to pressure gauges) to pressurize first the entire space that is heated and/or cooled and then the same space with the duct system blocked off. This method is less accurate than the duct testing method. The *duct testing method* uses a calibrated fan that gently

pressurizes the ducts and measures the airflow through the ducts to indicate total leakage. The duct tester consists of a portable fan with calibrated digital pressure gauges that is connected at the blower compartment of the air handler, or attached to the main return grill. The entire duct registers and grills are temporarily sealed, and the duct tester fan is turned on to pressurize the system. The fan pressure is read from the gauges and converted to an equivalent duct leakage rate in cubic feet per minute (cfm). If the amount of air loss falls outside acceptable limits, sealing will be required to correct the condition. This method of testing is preferred, because it measures low airflow accurately, and simulates what takes place under normal operating conditions.

11.8 Ductwork Sealing

The terms “seal” or “sealed” refers to use of mastic or mastic plus tape or gasketing, as appropriate. Liquids, mastics, gaskets, and tapes have all been used as sealants. Selecting the most appropriate sealant depends on joint configuration clearances, surface conditions, temperature, the direction of pressure, and pre-assembly or post-assembly placement. Tapes should not be applied to dry metal or to dry sealant. Foil tapes are not suitable. Liquids and mastics should be used in well ventilated areas, and the precautions of manufacturers followed.

Seal all ducts, including ducts in conditioned space, in accordance with the minimum requirements of Tables 6.2.4.3A and B of *ASHRAE 90.1-1999*.

Approved sealants are flexible gaskets, fibre-reinforced mastic or mastic used with mesh tape. Sealants should be UL 181 listed, water based, non-toxic and water resistant with high solids content. Sealants used outdoors shall be rated for outdoor use and resistant to weather and solar degradation.

Mastic sealant utilized should be water-based, non-toxic and consist of at least 50% solids and be UL 181 approved.

Oil base caulking and glazing compounds should not be used.

Apply sealants according to the manufacturer’s instructions with proper surface preparation and in correct temperature conditions.

Gaskets should be made of durable materials such as soft elastomer butyl with adhesive backing.

Cloth-backed duct tapes should not be used. Pressure sensitive tapes in general are not recommended. Duct systems sealed with mastics generally exhibit lower leakage. If tape is used, methods and materials should comply with the *ADC - Flexible Duct Performance & Installation Standards*.

Return air chases should be sealed with mastic at the sole plate and top plate and at all corner joints and seams. The preferred method of return air design is a ducted return. Avoid using

building cavities for the return duct chase. If building cavities are used as return air duct, duct chase should be extended into the attic or between floors so that the section penetrating the floor joist or ceiling is continuous to prevent leakage.

Ducts that are sealed as described in table below are expected to have leakage less than 5 percent of the system operating airflow. All ducts should be sealed for SMACNA Seal Class B minimum—Engineer must specify. If less leakage is desired, seal all transverse joints in Class C.

SMACNA-HVAC Seal Classes of Ductwork

STANDARD DUCT SEALING REQUIREMENTS		
Seal Class	Sealing Requirements	Applicable Static Pressure Construction Class
A 2–5% Total System Leakage	All Traverse joints, longitudinal seams and duct wall penetrations	4"-WG and up (1000 Pa)
B 3–10% Total System Leakage	All traverse joints and longitudinal seams only	3"-WG (750 Pa)
C 5–20% Total System Leakage	Transverse joints only (Note- Any variable air volume system duct of 1" (250Pa) and ½" (125Pa) construction class that is upstream of the VAV boxes shall meet Seal Class C.	2" – WG (500 Pa)

Ensure that the ductwork connections to the air handling units or curb (as specified by the manufacturer) are sealed airtight and that the seals can withstand vibration. This is a common site for large leaks.

Provide airtight seals at duct connections to air outlets, duct access panels and equipment cabinet panels. These are commonly overlooked sites for leaks.

Do not apply sealant in spiral duct lock-seams. This can result in poor seam closure and less satisfactory control.

11.9 Volume Flow Rate Measurements

Usually in field, the average velocity in a duct or airway is measured with help of either "Pitot Tube or Anemometer". Then by multiplying this average velocity by the area of the duct at the

plane of measurement, the volume flow rate can be calculated. For example, if the mean velocity in a rectangular duct 12" x 24" is 1000 fpm, the volume flow rate is $12 \times 24 \times 1000/144 = 2000\text{cfm}$.

Anemometer: An instrument used for the measurement of air velocity.

- a. *Anemometer-Hot Wire:* This has a probe consisting of a very fine short length of wire (or small thermistor bead) attached to the end of a supporting tube. The wire is heated electrically, and measurements are made of the heat dissipated by the wire. The rate of heat dissipation is directly related to the velocity of the air passing the wire.
- b. *Anemometer- Rotating vane:* This consists of a disc of angled vanes attached to a rotating spindle and is usually mounted within a protective ring and supporting bracket. The speed at which the vane assembly rotates is a measure of the air velocity acting upon it. This speed may be sensed either electronically or by a counter mechanism.
- c. *Anemometer- Ultrasonic:* Clean air and gas flow velocity measurement with a "mini sensor". Using three energized "posts", sound waves are transmitted sequentially 3849 times every second. The time taken for a sound to travel from one post to another and for a wave to return over the same precise distance is measured. By using the speed of sound, @ 340.3 m/sec in standard air as a "carrier" the true velocity can be calculated with 100% certainty and repeatability. Any changes in ambient temperature, barometric pressure, RH and gas density conditions are rendered irrelevant permitting use in mixed air/inert gas density situations without any need for corrections, re-calibration or complex calculations.

11.10 Ductwork Pressure Balancing

One of the most important requirements for the design of a duct system is pressure balancing. The system pressure will be balanced when the fan pressure is equal to the sum of the pressure losses through each section of a branch. This is true for each system branch. Another different interpretation of pressure balancing is that pressure losses need to be balanced at each junction. If the sum of the pressure losses in a branch does not equal the fan pressure, the duct system will automatically redistribute air, which will result in air flows different from those designed. Designing a duct system means sizing the ducts and selecting the fittings and fans. Duct sizing is not the same as making pressure loss calculations although the two are commonly confused.

11.11 Duct Noise Considerations

Sound becomes noise when it is objectionable to the occupants of a building. Without proper precautions, sounds generated by HVAC systems may become irritating noise.

Noise in duct systems is caused by turbulence within the system and transmitted noise from the HVAC unit. Strategies that reduce duct system pressure drop also help reduce noise. The

following guidelines will help provide a duct design that is both energy efficient and acoustically acceptable.

Sound is a by-product of energy supplied to the moving components of HVAC equipment. The major source of noise in a duct system is the fan. The selected operating point of a fan has a major effect on the acoustic output level or noise generated; the point of maximum efficiency produces the best acoustical effect. However, during system operation when dampering occurs, the operating point moves up into a less efficient region, adding low-frequency rumble. Selecting a fan operating point at a lower total pressure than the maximum for clean filters will also avoid or reduce noise problems. Undersized fans operating at higher shaft speeds produce more noise, and oversized fans operating at lower shaft speeds create more low-frequency noise than fans operating at maximum efficiencies.

The following recommendations concerning duct-generated noise are presented in the HVAC Applications chapter, "Sound and Vibration Control" of the ASHRAE HVAC Applications Handbook, 2003:

1. Reduce air velocities; Duct velocities of 4 m/s (800 fpm) or less generate no audible noise.
2. Reducing the design friction rate also reduces the duct velocity, which reduces duct noise from turbulence. Fittings designed for reduced pressure losses also have fewer problems from turbulence induced noise. Note that although minimizing fittings reduces pressure loss, the duct system should have at least two turns between the HVAC unit and the room to reduce noise transmission.
3. Lower duct pressure drop reduces fan speed, which also reduces fan noise. Spiral round duct, which has better pressure drop characteristics, is also more rigid than rectangular duct, reducing the drum effect from duct vibration.
4. Avoid abrupt changes in duct cross sections; most straight ductwork naturally attenuates noise; provide smooth transitional duct branches, take offs, and bends;
5. Fittings such as elbows, dampers, branch take offs, grilles, registers, diffusers, air-handling light fixtures, and variable inlet vanes either create or attenuate noise, depending on their geometry and air velocity. Acoustic lining increases noise attenuation.
6. Use mechanical isolation, shields, baffles, and acoustical liners.
7. Use vibration isolators between the equipment and the building to avoid transmission of vibration and noise through the structure.
8. Use equipment rooms that can be acoustically isolated if necessary.
9. Registers and diffusers should be selected to minimize noise output.

10. Equipment spaces should be separated as far as possible from spaces with demands for low background sound levels.
11. Use of flexible fabric connections is recommended at points where the ductwork connects equipment subject to vibration.
12. Avoid locating the HVAC unit in a space immediately adjacent to the occupied space. Provide vibration isolation and sufficient acoustic insulation for the walls of the mechanical room in situations where this is unavoidable.
13. Install Attenuators: Devices for reducing the amplitude of a source of energy.

The HVAC industry has established noise criteria (NC) values for evaluating the acceptability of sound levels. NC values for different types of buildings range from 30 to 40 decibels. A decibel is a unit of comparative sound measurement (a whispered conversation at a distance of 6 ft. from the ear, for example, has a sound pressure level of 30 decibels).

11.12 Energy Conservation

Typical duct systems lose 25 to 40 percent of the heating or cooling energy put out by the central furnace, heat pump, or air conditioner. Homes with ducts in a protected area such as a basement may lose somewhat less than this, while some other types of systems (such as attic ducts in hot, humid climates) often lose more. Designing air distribution systems to avoid excessive duct lengths/fittings, high air velocities, and pressure drop can have a major impact on energy. Energy-efficient duct design also includes locating ducts to minimize thermal and leakage losses. These practices promote proper air distribution while reducing noise and energy use. Duct systems lose energy in three ways:

1. The first way is through conduction of heat through the duct walls. In conduction, the hot air inside the ducts warms the duct walls and they, in turn, warm the cold air surrounding them. If this warmed air escapes to the outdoors, like into unheated attics, basements or crawl spaces, this heat will never reach the rooms and will be wasted. Ducts running through unconditioned spaces like an attic or crawlspace should be insulated. Ducts in conditioned space are the most energy-efficient duct location. Heat gains and losses are minimized and go directly to the conditioned space.
2. The second way that energy can be lost is through leakage of heated air into and out of ducts, through accidental holes in the ducts or through open spaces between poorly connected sections of ductwork. Leaky supply ducts causes depressurization of the structure, and outside air is forced in through cracks in the envelope. Leaky return ducts cause pressurization, which forces conditioned inside air out of the structure. Sealing both supply and return ducts minimizes energy loss by infiltration. Some infiltration occurs

naturally, but when the fan of the central unit is turned on, infiltration is typically two to three times greater than when the fan is off.

3. The third way ducts cause energy loss is through infiltration. Pressure imbalances caused by faulty ducts can cause air to leak more readily through holes and cracks in the walls or ceiling of the structure. This is called air infiltration.

11.13 Coordination between Design Specialties

The process of design review includes a spot check to verify that the mechanical design is coordinated with the electrical, structural, and architectural design. Many of the following coordination checks will ensure energy efficiency in addition to verifying systems integration:

1. Is the structural support adequate in the areas where mechanical equipment will be located?
2. Do the architectural and structural details provide the necessary sound isolation and moisture protection in mechanical areas?
3. Is intake and exhaust penetrations through walls adequately sized to prevent high pressure drops and moisture penetration?
4. Are chase sizes large enough to allow adequately sized ductwork?
5. Are the structural clearances around chases and other areas with large duct and piping mains sufficient to allow the systems to be installed without high pressure drops?
6. Is there sufficient space above the ceiling and below the structure to allow the necessary mechanical system to be routed in conjunction with the electrical, plumbing and specialty systems without an excessive number of offsets and/or restricted duct sizes?
7. Have general rules been established for routing ducts, pipes, conduits and specialty systems through the ceiling cavity? If so, do they meet the requirements of the mechanical systems?
8. Is there a suitable access route to allow worn-out equipment to be removed and new equipment to be installed? Does this route contain adequate structural strength to support the equipment that might be moved through it?
9. Are the electrical service requirements coordinated with the requirements of the mechanical systems in terms of voltage, capacity, reliability, and source? An air-handling system that has its fans powered by the emergency system, its Direct Digital Control (DDC) controllers powered by an Uninterruptible Power Supply, and an interlock circuit on normal power may experience a few problems when there is a momentary power surge on the utility line.

10. If the project will use variable speed drives, who will specify them? If the drives require isolation transformers or line reactors, who is responsible for sizing and specifying them?
11. Have the motor horsepower requirements changed since design development?
12. Has the type of starter that will be used for large machinery been coordinated with the electrical designer? Often, changing the type of starter or the voltage that is used to serve a large motor can improve electrical system performance and reduce first costs.

These coordination issues have ripple effects with significant implications for energy and resource conservation. For example, if a coordination problem between a mechanical system and a structural element is not resolved at design, the field solution may require additional fittings. These fittings will introduce pressure drops that will persist for the life of the system or possibly the life of the building. As another example, consider an equipment room with a poor access route. The lack of suitable access may delay the replacement of an existing, outdated piece of equipment with a more efficient machine simply because the cost to bring the new equipment into the building is too high.

12.0. DUCTWORK TESTING & SYSTEM PERFORMANCE

The following are testing requirements and procedures that must be followed to ensure that the HVAC system has been properly installed. The tests are designed to determine whether:

1. Room-by-room air flows are correct;
2. Total supply is as designed;
3. Total return + exhaust = total supply;
4. Ducts, plenum, and air handler are tight;
5. Static pressure is correct

Test the system to ensure that it performs properly, by (1) verifying HVAC equipment sizes installed are those specified, (2) measuring duct leakage, and measuring either (3) fan flow or (4) supply and return flows and plenum static pressures:

Air conditioner sensible capacity must be no more than 15% greater than the calculated sensible load; fan flow must be greater than 350 CFM/ton; check that the correct size air handler is installed.

Ensure that the duct system does not leak substantially:

1. A rough system, including both supply and return but without the air handler, should not leak more than $0.03 \times \text{conditioned floor area (ft}^2\text{)}$ per system measured in CFM @ 50 Pa;

2. The finished installation, including supply, return, the air handler and finished registers, must not leak more than $0.07 \times$ conditioned floor area (ft^2) per system measured in CFM @ 50 Pa;

Measure air handler air flow and static pressure across fan; ensure that total air handler output is within 5% of design and manufacturer specifications at a static pressure within 0.1 in wg of design.

Supply and return air flow, and static pressure requirements: Ensure that supply and return flows are correct, and that the static pressure across the fan is correct:

1. Measure room-by-room air flows to ensure that each register is within 15% of Manual D design air flow, and that the entire supply is within 5% of design;
2. Measure return air flow to ensure that it is within 5% of the total supply air flow;
3. Test static pressure drop across the blower to ensure that it is within 0.1 in wg of design and manufacturer specifications.
 - Duct leakage can be determined using a pressurization or depressurization technique;
 - Fan flow, supply flow and return flow measurements, use a calibrated flow hood. Do not use a pitot tube, or any type of anemometer to determine these air flows;

Static pressure drop across the fan is measured using a small probe in the return plenum and in the supply plenum.

12.1 Provisions during Design for Testing, Adjusting, and Balancing

It is important for system air to get to the occupied space with minimal losses caused from leakage and resistance, with proper mixing of air, and without temperature changes from heat gains or losses. Also important are the noise, drafts, and efficiency with which air is delivered. The means to meet these requirements are the proper design of ductwork and outlets.

The designer should give special attention to the balancing and adjusting process during the design. It is necessary that the balancing capability be designed into the system initially. Below are some considerations to make when designing duct systems.

1. Sufficient lengths of straight duct must be provided in an accessible area to allow the TAB personnel to perform their function properly. This also applies in TAB work of the critical branches of the distribution system.
2. Application of single blade, quadrant volume dampers just behind diffusers and grilles may tend to throw air to one side of the outlet, preventing uniform airflow across the outlet face or cones.

3. A slight opening of an opposed blade volume damper will generate a relatively high noise level as the air passes through the damper opening under system pressure.
4. To minimize generated duct noise at volume dampers, indicate damper locations at least two diameters from a fitting, and as far as possible from an outlet.
5. All portions of the main return air duct system require manual balancing dampers at each duct inlet.
6. Avoid placing a return air opening directly in or adjacent to the return air plenum without a noise attenuator. Lining of the duct behind the opening normally will not reduce the transmitted noise to acceptable levels.
7. Mixing boxes should be located so the discharge ductwork will minimize air turbulence and stratification.
8. Provide the necessary space around components of the duct system to allow a TAB technician to obtain proper readings. Allow straight duct sections of 7½ inch duct diameters from fan outlets, elbows, or open duct ends for accurate traverse readings.
9. Ductwork to and from air conditioning equipment should be designed carefully so stratified air may be mixed properly before entering branch ducts or equipment.
10. Splitter-type dampers should be regarded as air diverters only, with maximum effectiveness when present on duct systems exhibiting low resistance to airflow.
11. Manually operated, opposed blade or single blade, quadrant-type volume dampers should be installed in each branch duct takeoff after leaving the main duct to control the amount of air entering or leaving the branch. Turning vanes should be installed so air leaving the vanes is parallel to the downstream duct walls. Double thickness or single thickness extended edge turning vanes should be utilized in all rectangular elbows.
12. Manual volume dampers should be provided in branch duct takeoffs to control the total air to the face dampers of the registers or diffusers. Use of extractors is not recommended because they can cause turbulence in the main trunk duct thereby increasing the system total pressure, and affecting the performance of other branch outlets downstream. Register or diffuser dampers cannot be used for reducing high air volumes without inducing objectionable air noise levels.
13. Do not use extractors at branch or main duct takeoffs to provide volume control. Extractors are principally used to divert air to branch ducts.
14. Adequate size access doors should be installed within a normal working distance of all volume dampers, fire dampers, pressure reducing valves, reheat coils, mixing boxes,

blenders, constant volume regulators, etc. that require adjustments within the ductwork. Coordinate locations with the architect.

15. Provide for test wells, plugged openings, etc., normally used in TAB procedures.
16. Splitter-type dampers should be regarded as air diverters only, with maximum effectiveness when present on duct systems exhibiting low resistance to airflow.
17. Manually operated, opposed blade or single blade, quadrant-type volume dampers should be installed in each branch duct takeoff after leaving the main duct to control the amount of air entering or leaving the branch. Turning vanes should be installed so air leaving the vanes is parallel to the downstream duct walls. Double thickness or single thickness extended edge turning vanes should be utilized in all rectangular elbows.
18. Manual volume dampers should be provided in branch duct takeoffs to control the total air to the face dampers of the registers or diffusers. Use of extractors is not recommended because they can cause turbulence in the main trunk duct thereby increasing the system total pressure, and affecting the performance of other branch outlets downstream. Register or diffuser dampers cannot be used for reducing high air volumes without inducing objectionable air noise levels.
19. Do not use extractors at branch or main duct takeoffs to provide volume control. Extractors are principally used to divert air to branch ducts.
20. Adequate size access doors should be installed within a normal working distance of all volume dampers, fire dampers, pressure reducing valves, reheat coils, mixing boxes, blenders, constant volume regulators, etc. that require adjustments within the ductwork. Coordinate locations with the architect.
21. Provide for test wells, plugged openings, etc., normally used in TAB procedures.

13.0. DUCT CLEANING

Duct cleaning generally refers to the cleaning of various heating and cooling system components of forced air systems, including the supply and return air ducts and registers, grilles and diffusers, heat exchangers heating and cooling coils, condensate drain pans (drip pans), fan motor and fan housing, and the air handling unit housing.

There was also some question as to when duct cleaning should be done and how the job could be validated. According to Environment Protection Agency (EPA), duct cleaning has never been shown to actually prevent health problems. Neither do studies conclusively demonstrate that particle (e.g., dust) levels in homes increase because of dirty air ducts. This is because much of the dirt in air ducts adheres to duct surfaces and does not necessarily enter the living space. It is important to keep in mind that dirty air ducts are only one of many possible sources of particles that

are present in homes. Pollutants that enter the home both from outdoors and indoor activities such as cooking, cleaning, smoking, or just moving around can cause greater exposure to contaminants than dirty air ducts. Moreover, there is no evidence that a light amount of household dust or other particulate mater in *air ducts* poses any risk to your health. You should consider having the air ducts in your home cleaned if:

1. There is substantial visible mold growth inside hard surface (e.g., sheet metal) ducts or on other components of your heating and cooling system. There are several important points to understand concerning mold detection in heating and cooling systems:
 - You should be aware that although a substance may look like mold, a positive determination of whether it is mold or not can be made only by an expert and may require laboratory analysis for final confirmation. For about \$50, some microbiology laboratories can tell you whether a sample sent to them on a clear strip of sticky household tape is mold or simply a substance that resembles it.
 - If you have insulated air ducts and the insulation gets wet or moldy it cannot be effectively cleaned and should be removed and replaced.
 - If the conditions causing the mold growth in the first place are not corrected, mold growth will recur.
2. Ducts are infested with vermin, e.g. (rodents or insects); or
3. Ducts are clogged with excessive amounts of dust and debris and/or particles are actually released into the home from your supply registers.

In 1989, the National Air Duct Cleaners Association (NADCA) was formed by members of the duct cleaning industry. This organization adopted a standard in 1992 entitled: *NADCA Standard 1992-01, Mechanical Cleaning of Non-Porous Air Conveyance System Components*. This standard provides performance requirements and evaluation criteria for the mechanical cleaning of non-porous ductwork, fans, coils, and other non-porous components of commercial and residential air conveyance systems.

13.1 Duct Cleaning Methods

Methods of duct cleaning vary, although standards have been established by industry associations concerned with air duct cleaning. Typically, a service provider will use specialized tools to dislodge dirt and other debris in ducts, and then vacuum them out with a high-powered vacuum cleaner.

Common duct cleaning methods include (1) Contact vacuuming, (2) Air washing and (3) Power brushing

1. **Contact Vacuuming:** Contact vacuuming involves cleaning the interior duct surfaces by way of existing openings and outlets or, when necessary, through openings cut into the ducts. The

vacuum unit should exhaust particles outside the space or otherwise use HEPA filtering if it is exhausting into an occupied space. Starting at the return side of the system, the vacuum cleaner head is inserted into the section of the duct to be cleaned at the opening furthest upstream, and then the vacuum cleaner is turned on. Vacuuming proceeds downstream slowly enough to allow the vacuum to pick up all dirt and dust particles.

2. **Air Washing:** In the air washing method, a vacuum collection unit is connected to the downstream end of the duct section through a suitable opening. The vacuum unit should use HEPA filtering, if it is exhausting into an occupied space. The isolated section of duct being cleaned should be subjected to a minimum of 1" negative air pressure to draw loosened materials into the vacuum collection system. Take care not to collapse the duct. Compressed air is then introduced into the duct through a hose equipped with a skipper nozzle. This nozzle is propelled by the compressed air along the inside of the duct. For the air washing method to be effective, the compressed air source should be able to produce between 160 and 200 psi air pressure and should have a 20-gallon receiver tank. This method is most effective in cleaning ductwork no larger than 24" x 24" inside dimensions. Inspection of each duct section and related components is performed to determine whether the duct is clean.
3. **Power (Mechanical) Brushing Method:** In the power brushing method, a vacuum collection unit is connected to the duct in the same way as with the air washing method. Pneumatic or electric rotary brushes are used to dislodge dirt and dust particles, which become airborne and are then drawn into the vacuum unit. Power brushing can be used with all types of ducts and fibrous glass surfaces, if the bristles are not too stiff and the brush is not allowed to remain in one place for a long time. Power brushing usually requires larger access openings in the duct in order to allow for manipulating the equipment. The rotary brush is inserted into the duct section at the opening farthest upstream from the vacuum collector. The brush is moved downstream to dislodge dirt and dust particles. Inspection of each duct section and related components is performed to determine if the duct is clean. When the section of duct is clean, the brush is removed from the duct and inserted through the next opening, where the process continues.

In addition, the service provider may propose applying chemical biocides, designed to kill microbiological contaminants, to the inside of the duct work and to other system components. Some service providers may also suggest applying chemical treatments (sealants or other encapsulants) to encapsulate or cover the inside surfaces of the air ducts and equipment housings because they believe it will control mold growth or prevent the release of dirt particles or fibers from ducts. These practices have yet to be fully researched and you should be fully informed before deciding to permit the use of biocides or chemical treatments in your air ducts. They should only be applied, if at all, after the system has been properly cleaned of all visible dust or debris.

Remember, duct cleaning alone does not solve IAQ problems. Dirty ventilation systems are most often the effect, not the cause of, poor indoor air quality. However, when duct cleaning is done

along with a program of regular building maintenance, it can help to reduce the threat of indoor air pollution. If you decide to have your heating and cooling system cleaned, it is important to make sure the service provider agrees to clean all components of the system and is qualified to do so. Failure to clean a component of a contaminated system can result in re-contamination of the entire system, thus negating any potential benefits.

Summarizing

The purpose of air conditioning ductwork is to deliver air from the fan to the diffusers which distribute the air to the room.

Air Moves through the Ductwork in Response to a Pressure Difference Created by the Fan

The necessary pressure difference will be a function of the way the ductwork is laid out and sized.

The objective of duct design is to size the duct so as to minimize the pressure drop through the duct, while keeping the size (and cost) of the ductwork to a minimum.

Proper duct design requires knowledge of the factors that effect pressure drop and velocity in the duct.

Round, smooth galvanized-steel ducts are recommended for maximum air-carrying capacity with minimum pressure loss. Round ducts require 27 percent less metal per unit of air-handling capacity than rectangular ducts and have lower installation costs, which may result in substantial capital cost savings.

Rectangular metal duct is the most flexible when it comes to fitting within limited spaces, and is used in many duct systems with pressures under 2.0 in-WC particularly when the installing contractor has a sheet metal shop. When rectangular ducts must be used due to space limitations, keep the width-to-height ratio close to 1:1 for lower pressure drop.

In systems with pressures less than 2.0 in. wg, it is common to find fibreglass ducts instead of metal. Fibreglass ducts consist of a rigid fibre board and a reinforced aluminium applied facing. Fibreglass ducts are available in both round and rectangular construction.

In medium- and high-pressure systems (above 4.0 in. wg) it is common to find round and flat oval type ducts. These ducts are easier to seal and prevent leaks than rectangular ones.

Leaks with medium- and high-pressure systems can create considerable noise. Sealing materials include gaskets, pressure-sensitive tapes, embedded fabrics, mastics, and liquids.
